

CATALOG

ABB Ability™ System 800xA 6.1

Product Catalog



Table of contents

008	System 800xA Extended Automation	01
010	System 800xA, System Capabilities	01
012	System 800xA Software	01
012	License	
013	800xA 6.1 System, Lifecycle Management – System Expansion	01
013	Automation Sentinel Program	
014	System 800xA 6.1 System Identifier	01
014	Control System Lifecycle Management Program	
014	System Identifier	
015–040	System 800xA 6.1	02
015	Automation Sentinel Upgrade Orders	
015	System 800xA Base System	
016	Tag Expansion	
017	Subscriber System Tags	
018	System 800xA Applications	
018	Connectivity	
020	System Extensions	
020	Cyber Security	
021	Control Room Solutions	

022	Control Room Prestudy
023	Operator Workplaces
024	Extended Operations
024	Public Addressing
024	Live Video System
025	Batch Management
026	Standard Engineering Tools
026	Professional Engineering Tools
027	Information Management
027	System 800xA History
028	IM Historian Server
029	IM Historian
030	Control Software Licenses
031	Communication Interface Software Licenses
032	Safety
032	Asset Optimization
033	Asset Monitors
033	Device Management & Fieldbuses
035	Libraries
036	Process Industries Application Libraries
036	PIAL Media
036	Process Control Device Library
036	Process Industries Application Libraries
037	Additional Control Device Library Licenses
037	PCDL Application Engineering

037	Process Control Equipment Library	
038	Process Control Equipment Library Licenses	
038	Additional Control Equipment Library Licenses	
039	PCEL Application Engineering	
039	ProBase	
040	Localization	
041–061	AC 800M Processor Units	03
042	AC 800M Controllers selection guide	
046	Hardware Upgrade orders	
046	System Units	
047	AC 800M Processor Units	
049	AC 800M High Integrity Units	
051	Extra Batteries	
051	Control Network	
051	Serial Interfaces on TP830	
052	AC 800M Controller and Communication Interface selection guide	
054	Serial Communication Interface	
054	MODBUS TCP	
054	PROFIBUS DP	
054	PROFINET IO	
055	FOUNDATION Fieldbus	
055	IEC 61850	
055	Ethernet/IP	
056	Advant Fieldbus 100	

056	MasterBus 300	
056	S100 I/O Bus	
057	Satt I/O	
057	INSUM	
057	DriveBus	
058	Bus Accessories	
059	AC 800M Power supply and Voters selection guide	
061	AC 800M Power supply and Voters	
061	AC 800M Mounting Rails	
062–066	Select I/O	04
063	Select I/O Selection guide	
064	Extended warranty for Select I/O Hardware	
064	ISA-S71.04 level G3 compliance	
064	Field Communication Interface	
064	I/O Modules	
065	High Integrity I/O Modules	
065	Module Termination Units	
066	ModuleBus Communication Parts	
066	Empty Slot Protectors	
066	Power Supply	
067–089	S800 I/O Modules	05
068	S800 I/O Modules	
069	S800L I/O Modules	
070	S800 I/O Modules Selection guide	
071	S800 I/O Communication interfaces	

075	Extended warranty for S800 I/O Hardware	
075	ISA-S71.04 level G3 Compliance	
075	Field Communication Interface	
076	Upgrade Kit and Tool Cables	
077	S800 I/O Modules	
080	Pulse Counting Modules	
081	Label sets for I/O Modules	
081	High Integrity I/O Modules	
082	Module Termination Units	
084	S800L I/O Modules	
084	Label sets for S800L I/O Modules	
085	ModuleBus Communication Parts	
087	S800 I/O Power Supply and selection guide	
089	Power Supply	
090–102	S900 Remote I/O System	06
091	Ex zone 1 system components	
093	Ex zone 2 system components	
095	S900 Remote I/O System – Safe area system components	
097	Accessories	
098	Field Housing S900-FH660S	
098	Field Housing S900-FH680S	
099	Accessories	
099	FOUNDATION Fieldbus Network Components	
100	PROFIBUS Network Components	

101	S800 I/O, S900 I/O, Fieldbus and AC800M	—
101–102	Media	07
101	ABB Ability™ System 800xA	
102	Library	
102	Dongles	
102	Base System – Engineering Systems	
102	Base System – Engineering Systems options	—
103	Field-Kit System	08
104–110	Panel 800 Version 6.2	09
105	Specifications Panel 800 Version 6	
106	Lifecycle Management Program	
107	Panel Builder 800	
107	Operator Panels	
109	Dongles	
109	Accessories	—
111–116	System 800xA Networks	10
112	System 800xA Networks selection guide	
114	Network switches	
114	Network routers/firewalls	
113	Network accessories	
113	Modular Transceivers (SFPs)	
116	Specifications Optical Transceivers	—
117	Extended Warranty Time S800 I/O, S900 I/O, Fieldbus and AC 800M	11
118	Reference and System 800xA Hardware Selector	11

ABB Ability™ System 800xA Extended Automation

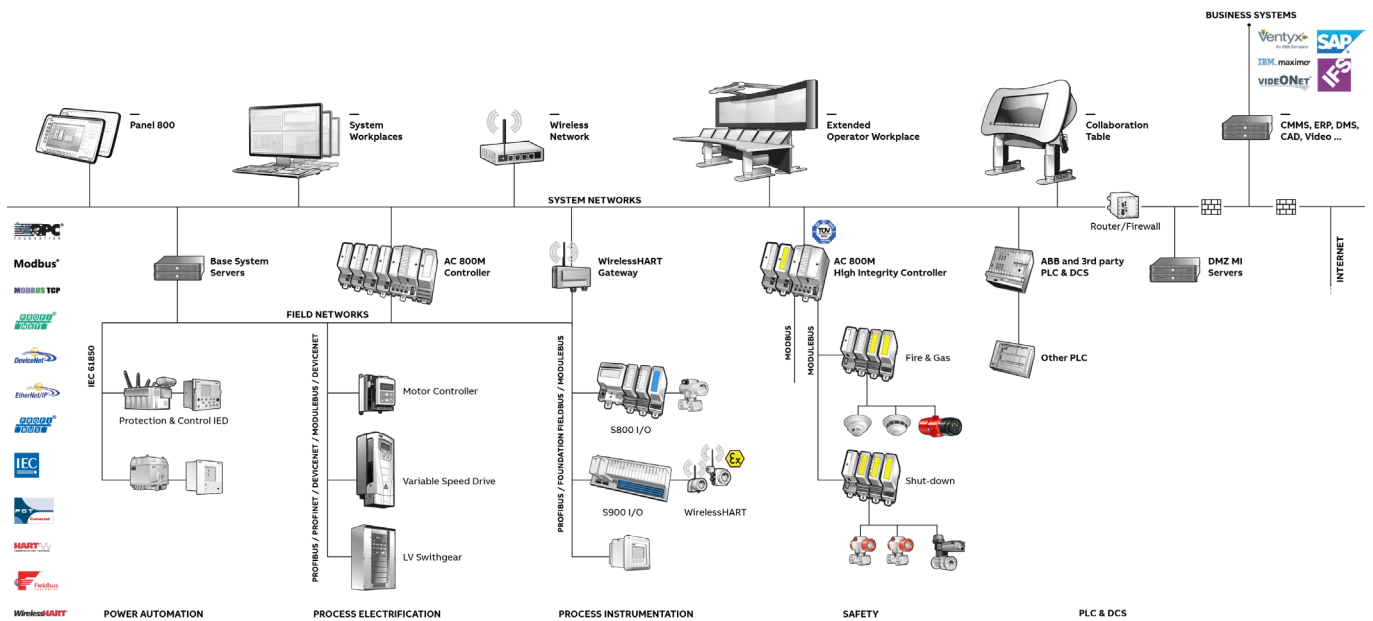

System 800xA is not only a DCS (Distributed Control System) it's also an Electrical Control System, a Safety System and a collaboration enabler with the capacity to improve engineering efficiency, operator performance and asset utilization.

Promoting collaboration

Collaboration between people and systems is a necessity to increase engineering efficiency, asset utilization, energy savings, and operator effectiveness. System 800xA's 'xA' stands for Extended Automation and utilizes the system architecture which was built for collaboration. System 800xA is the only automation platform that has the ability to engineer, commission, control, and operate automation strategies for process, power, electrical and safety in the same, redundant, reliable system. Also, facilitating collaboration is System 800xA's pre-integrated applications such as a full featured historian, asset optimization, batch management and much more.

System 800xA

ABB's award winning System 800xA provides you with a better way to achieve measurable productivity and profitability improvements. System 800xA extends the scope of traditional DCS systems to include all automation functions in a single operations and engineering environment; enabling your plants to perform smarter and better at substantial cost savings.

Embracing the principles of open, real-time networking, System 800xA provides a scalable solution that spans and integrates loop, unit, area, plant, and inter plant controls. From providing a secure foundation with robust, but flexible, base level regulatory and sequence control to higher level management and advanced control functions that include safety controls, batch management, maintenance management, information management, and network management solutions, System 800xA meets the application needs of a wide variety of industries.

System 800xA provides you with a secure, reliable control environment with minimum effort through built-in security features such as access control, user authentication, and audit trail capability. ABB enhances secure system operations by actively participating on security standards committees, conducting threat-modeling studies, and incorporating "safe design" practices into product development.

Based upon the Aspect Object technology and a common set of hardware, System 800xA seamlessly integrates traditionally isolated DCS and Safety systems. SIS realization is achieved by either utilizing individual controllers or through dedicated applications within the same controller. With this embedded control and safety architecture, System 800xA reduces costs significantly; achieving the objectives of both systems – maximum plant availability at minimum risk.

For more information about System 800xA please visit our web: [solutions.abb/800xa](https://www.abb.com/solutions/800xa)

System 800xA

System Capabilities

System 800xA from ABB is a control system that enables plant wide collaboration between people, systems and equipment. System 800xA utilizes a system architecture built for collaboration in a fully redundant, reliable environment.

Removing the barriers in traditional distributed control systems, System 800xA provides a collaboration environment that is required to increase productivity while reducing risk and total cost of ownership.

System 800xA Capabilities

Tags	120,000
Total number of Clients, normal or remote (nodes with one or several workplaces)	80
I/O channels	From a hundred to over 1,000 per controller depending on CPU type and application.
Operator screens per system	160
Operator screens per Operator Workplace	4
Operator Workplaces, normal or remote	80
Engineering Workplaces	20
Remote Engineering Workplaces	5
Information Management Workplaces	80
Desktop Displays for trends and events	150
Batch Workplaces	40
Nodes in one control network segment (excl. domain server and controllers)	100
Aspect Services redundancy	1 (single, redundant 1oo2 or 2oo3)
AC 800M Connectivity services	8 (16 if redundant)
AC 800M controllers per connectivity services	48 (Application Dependent)

System 800xA Capabilities

PROFIBUS Connectivity services	8 (16 if redundant), 2,500 devices per server
HART Connectivity services	8 (16 if redundant), 2,500 devices per server
Foundation Fieldbus Connectivity services	8 (16 if redundant), 4,000 devices per server
PLC Connect services	3 (6 if redundant), 25,000 signals per server
Asset Optimization services	4
Multisystem Integration Subscribers	2
Multisystem Integration Providers	20
Connectivity servers, total	12 (24 if redundant)
Application servers	10
Batch servers	1 (single or redundant 1oo2)
Information Management servers (used as single, redundant, or consolidating servers)	6
Supported Fieldbuses	Foundation Fieldbus, PROFIBUS, PROFINET, HART
Electrical Integration	IEC 61850
Standard Serial Protocols	RS232C: MODBUS RTU/TCP, 3964R, Comli
External application communication	OPC, OLE-DB, ODBC
Network	Ethernet TCP/IP Redundant
Network device supervision	SNMP
Operating System	Server: Windows Server 2012 R2 / 2016 (64 bit US English Version), depending on node type Client: Windows 8.1 Professional/Enterprise (64 bit US English Version), Windows 10 (LTSC 2015/2016)

Performance and capacity	
Graphical displays	Unlimited (depending on available Hard disk space)
Display exchange time	Standard Main Faceplate: ≤1 second. Graphic display with 100 objects: ≤1 seconds
Command response time (order to indication)	<2 seconds
Reports	Unlimited
Alarm and event lists	100
X-Y plots	Unlimited
Active Batch Phases	300
Asset Monitors	20,000
History Logs per system (Information Manager)	180,000
History Log disc space per value (Information Manager)	21 bytes
Stored OPC Messages (Information Manager)	12,000,000
History Logs per server (800xA History)	150,000
History Log disc space requirements (800xA History)	40 bytes
Stored OPC Messages (800xA History)	Time/Disc space limited
Event burst capacity	1000 alarms/second for 3 seconds plus 10/s for 15 minutes
Event storage disc space requirements	Storage per message: 6k bytes
Alarm/Event throughput/sec	30
OPC DA throughput (items per sec) per AC 800M Connectivity server	30,000
Max number of softpoint signals	25,000
Max number of soft events	10 /second
Scheduling Service capacity	Max. 200 simultaneous jobs per scheduling server
Calculation Services	10
Calculations/second	100
Write transactions/second	The Calculation server can write up to 10 values/second to process (AC 800M) objects
Calculations that may be queued waiting to be executed	1,000 calculations per Calculation server

System 800xA Software

The system installation is supported by the Automated Installation program. The Automated Installation program is a shell framework to ease the installation and configuration of your 800xA System.

Installation is never prevented due to lack of licensing, but licenses are required to unlock features for operating or engineering the system. Updates and security related software from non-ABB companies must be downloaded and installed separately, as guided from the Automated Installation program.

The Automated Installation program is supplied on the 800xA media box. The common part is to specify the system details of your system in the Automated Installation program System Planner and generate a unique setup package for each node (workstation) describing what should be installed from the 800xA media box, or a file server, onto each node, and how it should be configured.

The System 800xA Installer is installed on each node, and then the following steps are executed to install and configure your node:

- Windows configuration
- System Verifier tool
- System installation
- System configuration

The setup-files may also reside on the file server. Windows configuration configures the environment (IP address, hostname, Windows components, and Windows services) connect to the workgroup or domain. The System Verifier tool checks for the necessary 3rd party software and where installations are required.

License

The central licensing system (CLS) is local to each system. Each system is ordered separately, and a separate license file is fetched for each system from the Software Factory. This also means that each system is managed individually updates and upgrades, as well as initial system installation.

The software or hardware described in the document is furnished under a license and may be used, copied, or disclosed only in accordance with the terms of such license.



800xA 6.1 System

Lifecycle Management – System Expansion

Automation Sentinel Program

Automation Sentinel is the control system life-cycle support program and is aimed at providing services for the maintenance, continuous enhancement and evolution of the ABB installed base of control systems.

Each and every control system under Automation Sentinel can make use, depending on the active subscription mode, of the following main program deliverables listed below:

Software Updates and upgrades

Automation Sentinel users have the exclusive right to receive control system software updates and upgrades:

- Automation Sentinel users with a Maintain subscription have the possibility to receive technical corrections, roll-ups, service packs and software revisions for the current 800xA software version in use.
- Automation Sentinel users with a Maintain Plus subscription receive all what the Maintain users are receiving PLUS software upgrades to move from any 800xA version to the latest available 800xA software version.
- Automation Sentinel users with a Maintain & Evolve subscription receive all what the Maintain Plus users are receiving PLUS the possibility to take an ABB heritage control system (and selected 3rd party control systems) all the way to the latest available 800xA software version.

Cyber and IT security reports and updates

Automation Sentinel users have the exclusive right to access IT security validation reports:

ABB reviews, tests and validates on a regular basis Microsoft security updates and 3rd party virus scanner software for compatibility with the 800xA control system. Automation Sentinel users will have access to all available cyber and IT security reports and updates for application as needed in order to ensure that the running control systems are better protected against any security risks which are encountered more often now than ever before. Each and every control system must be under Automation Sentinel before making use of the published IT security validation reports.

System Benchmark Tool

Automation Sentinel users will have the right to use, at no additional cost, the following service tools:

- 800xA Control System Software and Performance Benchmark
- 800xA Control System Security Benchmark

The above listed service tools are employed to perform health and security checks on the 800xA control system and generate 'Traffic light' reports of the findings.

Expert product technical support

Automation Sentinel users have access to ABB expert and R&D support organizations. This support is being provided for troubleshooting of product defects and issues they encounter during the validity of the subscription.

Read more about our Automation Sentinel Program here: <https://new.abb.com/control-systems/service/offerings/service-agreements>

Program Options	Maintain Basic	Maintain	Maintain Plus	Maintain & Evolve
Basic Deliverables	<ul style="list-style-type: none"> • IT Security verification and validation reports • Web access via My Control System and SolutionsBank • Access to expert product support (L3/L4 support) 			
Maintenance Deliverables	<ul style="list-style-type: none"> • Software maintenance updates & corrections • System status and performance Benchmark tool • Scalable discount on selected service products • Scalable discount on selected expansion HW & SW 			
Enhancement Deliverables	<ul style="list-style-type: none"> • New software versions & enhancements 			
Evolution Deliverables	<ul style="list-style-type: none"> • Evolution from ABB Heritage OCS and 3rd party control systems to the latest ABB control platform 			

System 800xA 6.1 System Identifier

Control System Lifecycle Management Program

Control System Lifecycle Management Program



Automation Sentinel is the ABB control system lifecycle management program for the Extended Automation, Freelance, Compact Product Suite, Symphony Plus and OCS product lines. ABB recommends its customers to use Automation Sentinel for all its installed control systems. With this program, customers can keep control software up-to-date and maintain a flexible path forward to new system software technology. It provides services to maintain and continually advance and enhance your ABB control system installation. You may choose the level of maintenance and upgrade support that works best for your immediate needs and long-term production targets.

Read more about our Automation Sentinel Program and its many valuable services here: <https://new.abb.com/control-systems/service/offerings/service-agreements>

Please contact your local sales representative for detailed information on the program and on how to order Automation Sentinel subscriptions.

01

System Identifier

800xA System Identifier	Article no.	
<p>800xA System Identifier 6.1 System identifier, used as identifier for each individual 800xA system. The ID must be used when ordering hardware and software to a system. After ordering this item a system license in design phase can be downloaded from SOFA.</p>	3BSE089949R1	

System 800xA 6.1

Remark

Remark
When System Software Expansion licenses are ordered, the Serial Number of the ABB Software License Certificate for the previously ordered System Software licenses must be stated on the order to the ABB Supplier.

Automation Sentinel Upgrade Orders

Automation Sentinel Upgrade	Article no.
	Automation Sentinel Upgrade 3BSE047992R1 Read more about our Automation Sentinel Program and its many valuable services here: https://new.abb.com/control-systems/service/offerings/service-agreements

02

Base System

System 800xA Base System

The base system is used as the base for 800xA production system, mulitsystem integration subscriber system and as Read only system. Tags can be added to all these systems.

Only one type of subscriber tags (ie. subscriber tags or read only subscriber tags) can be added to a subscriber system. A subscriber system can not be converted from read only to read and write and vice versa.

800xA Base System 6.1	Article no.
Includes one Operator Workplace, one Engineering Workplace, AC800M Connectivity, Redundant Aspect Server, Plant Explorer, Logging of Operator actions, Topology Status Viewer, Softpoint Server, Scheduler, Primary History Logs (logging of signals for Operator trends).	
800xA Base System 6.1	3BSE088740R1
800xA Production License 6.1	Article no.
Ordered to be able to download a production license to switch the system from Engineering Phase to Production Phase.	
800xA Production License 6.1	3BSE088741R1

Base System

Tag Expansion

Tags	Article no.	
All process objects with faceplate for operator interactions counts as a tag. (Total max 120,000. Can not be mixed with redundant tags)		
100 tags, non-redundant 6.1	3BSE088742R1	
1,000 tags, non-redundant 6.1	3BSE088743R1	
10,000 tags, non-redundant 6.1	3BSE088744R1	
One process object with faceplate for operator interactions count as a tag.		

Redundant Tags	Article no.	
All process objects with an operator faceplate counts as a tag. (Total max 120,000. Can not be mixed with non-redundant tags) Enables tag access through redundant Connectivity Servers.		
100 tags, redundant 6.1	3BSE088745R1	
1,000 tags, redundant 6.1	3BSE088746R1	
10,000 tags, redundant 6.1	3BSE088747R1	
One process object with faceplate for operator interactions count as a tag.		

Base System

Subscriber System Tags

Subscriber System Tags

Tags in the subscriber system in a Multisystem Integration configuration. These tags are Object with a faceplate that collects data from a provider system. Subscriber tags are only required in the subscriber system.

Subscriber tag is required for every provider tag that needs to be accessed from graphics, alarms, trends etc, in a subscriber system.

Note that non-redundant Multisystem Subscriber Tags can not be mixed with Multisystem Subscriber Redundant Tags. Note that Multisystem Subscriber Tags can not be mixed with Multisystem Read Only Subscriber Tags.

Multisystem Subscriber Tags	Article no.	
Tags in the subscriber system in a Multisystem Integration configuration.		
100 Multisystem Subscriber Tags 6.1	3BSE088748R1	
1,000 Multisystem Subscriber Tags 6.1	3BSE088749R1	
10,000 Multisystem Subscriber Tags 6.1	3BSE088750R1	

Multisystem Subscriber Redundant Tags	Article no.	
Tags in the subscriber system in a Multisystem Integration configuration. Enables tag access through redundant Connectivity Servers.		
100 Multisystem Subscriber Redundant Tags 6.1	3BSE088751R1	
1,000 Multisystem Subscriber Redundant Tags 6.1	3BSE088752R1	
10,000 Multisystem Subscriber Redundant Tags 6.1	3BSE088753R1	

Base System

System 800xA Applications

Multisystem Read Only Subscriber Tags	Article no.	
<p>Tags in a read only subscriber system in a Multisystem Integration Configuration. Read only subscriber systems provides aspect object enabled read only clients to office users. Subscriber tags are only required in the subscriber system.</p> <p>A subscriber tag is required for every tag that needs to be accessed in a provider system.</p> <p>Tag access is required for tags in graphics, alarms, trends etc. Note that Multisystem Read Only Subscriber Tags can not be mixed with Multisystem Subscriber Tags.</p>		
<p>100 Multisystem Read Only Subscriber Tags 6.1 Tags in a read only subscriber system in a Multisystem Integration Configuration.</p>	3BSE088754R1	
<p>1,000 Multisystem Read Only Subscriber Tags 6.1 Tags in a read only subscriber system in a Multisystem Integration Configuration.</p>	3BSE088755R1	
<p>10,000 Multisystem Read Only Subscriber Tags 6.1 Tags in a read only subscriber system in a Multisystem Integration Configuration.</p>	3BSE088756R1	
<p>Office Workplace – Read Only Client 6.1 Includes one local or remote read-only operator workplace, Excel based reporting aspects. Microsoft Excel is NOT included. Use of up to 2 screens is included. (Only in systems with read-only MI tags)</p>	3BSE088757R1	

02

Base System

Connectivity

Connectivity	Article no.	
<p>Note that there may be 800xA price list options that are not supported with a particular OCS controller. Please refer to the table "Available functions per Controller Connectivity" in the System Guide "Technical Data and Configuration Information". To check what connectivity combinations that are valid, use the Project Wizard or refer to the System 800xA System Guide for information.</p>		
<p>PLC Connect 6.1 Faceplates, graphical elements and means to communicate with PLC-systems. (one licence per system)</p>	3BSE088758R1	
<p>PLC Connect Dial-Up 6.1 Scaled on number of dial up lines in a system.</p>	3BSE088759R1	
<p>800xA for Advant Master 6.1 Faceplates, graphical elements and means to communicate with the system. (One license per system.) 800xA for Advant Master hardware (PU410) needs to be ordered separately. Please refer to price book Advant OCS with Master Software.</p>	3BSE088761R1	

Base System

Connectivity

Connectivity	Article no.	
Advant Master Central Backup 6.1 Backup and restore of applications for Advant Master controllers (AC410, AC450, MP200/1, SG400) One license per system. Requires 800xA for Advant Master.	3BSE088762R1	
800xA for Harmony 6.1 Faceplates, graphical elements and means to communicate with the system. (one licence per system) 800xA for Harmony hardware need to be ordered separately.	3BSE088763R1	
800xA for AC 870P / Melody 6.1 Graphical elements and means to communicate with the system (Faceplates not included) (One licence per system.)	3BSE088764R1	
800xA for MOD 300 6.1 Faceplates, graphical elements and means to communicate with the system. (One license per system). 800xA for MOD 300 hardware (PU410/PU412) needs to be ordered separately. Please refer to price book Advant OCS with MOD 300 Software.	3BSE088765R1	
800xA for DCI 6.1 Faceplates, graphical elements and means to communicate with the Harmony Distributed Control Unit (HDCU) (one licence per system). Includes: Batch connectivity, VB6 and PG2 faceplates, HDCU maintenance functions.	3BSE088766R1	
800xA for Safeguard 6.1 Faceplates, graphical elements and means to communicate with the system. Note: Requires also 800xA for Advant Master.	3BSE088767R1	
800xA for AC 100 6.1 Faceplates, graphical elements and means to communicate with the AC 100 Controller, OPC server included.	3BSE88768R1	

Base System

System Extensions

System Extensions	Article no.
Point of Control 6.1 Collaboration based transfer of plant operation responsibility between locations and users.	3BSE088770R1
800xA OPC Client Connection 6.1 This enables third party OPC clients to connect to 800xA via the 800xA. OPC server, includes OPC DA, AE & HDA. One per external access.	3BSE088771R1
OLE-DB Real Time Data Client Connection 6.1 Allows realtime system data to be accessed via an OLE-DB interface. One per external access.	3BSE088772R1
SMS and e-mail Messaging 6.1 Sending messages based on alarm and event information to user devices such as mobile telephones, e-mail accounts and pagers.	3BSE088773R1
Calculation Engine 6.1 Provides the ability to run mathematical calculations on any available System 800xA aspect property or attribute. One license per server or redundant server pair.	3BSE088774R1
Snapshot Reports 6.1 Makes it possible to create aspects that automatically executes a query and produces a report consisting of properties of objects in the system.	3BSE088775R1
CAD Viewer license 6.1 View CAD drawings in DXF and DWG formats stored in aspects. DWG (version 13, 14, 2000, 2004, 2007, 2010) and DXF (version 12, 13, 14, 2000, 2004, 2007, 2010)	3BSE088776R1

02

Base System

Cyber Security

Cyber Security	Article no.
Digital Signature 6.1 Makes it possible to digitally sign aspects to ensure that data is kept unchanged after approval.	3BSE088777R1
Advanced Access Control 6.1 Reauthentication, double reauthentication and inactivity logout.	3BSE088778R1
Audit Trail 6.1 Logging of all user initiated actions in a system. e.g. graphics editing, control logic editing, batch recipe editing and start/stop of servers etc.	3BSE088779R1
800xA Event Forwarder The Windows event log updated with 800xA events so that e.g. a security information and event management (SIEM) system can be updated with this information. No SEIM HW or SW included. (one per system)	3BSE088780R1

Operations

Control Room Solutions

Control room operators make hundreds of decisions every working day – decisions that have a great impact on productivity, quality, and safety. What's more, the more alert, stimulated and harmonious they are, the better the decisions they make. For plant and control room managers, the key question is thus how to create and maintain operator well-being at levels that ensure their very best performance.

An operator environment designed with human factors in focus can convert potentially dangerous fatigue and distraction into proactive alertness that extracts the very best from every individual – in both routine operations and critical situations. Operator well-being is a key success factor for safe, productive and reliable operations.



24/7 control room solutions designed for the long-run and built to last

Equipment such as Control room equipment, chairs, desks, sound absorbers, cap desks, operator desks and other adjacent accessories. The equipment is marketed along an extensive knowledge about control room design and human factors. Collaboration is a key word and is used from a workflow perspective, analyzing operations in normal and critical situations and how collaboration is enhanced through design are interesting values for the end user operations. The equipment itself might not be the main competitive advantage, but in combination with their know-how this offering is highly interested to almost any projects.

By involving ABB in a control room pre-study, you get the unique possibility to create a control room environment that perfectly suits your needs and individual situation of operations. The pre-study focuses on human factors interacting with 800xA and uses high standard control room equipment in a very cost efficient way.

Operator information overviews are built to match the physical dimensions and personal preferences of each individual. With motorized sit/stand desk-height, screen adjustment options, light and sound settings, each environment

represents the ultimate in form and function. Designed to keep operators alert even during calm or monotonous periods, the desks and auxiliary products are bio-mechanically optimized, appealing to use and built to last.

The main purpose of this Product guide is to give a good overview and understanding of products specified to be used with 800xA. The offering includes other desk series and adjacent equipment suitable for 24/7 environments. To fully comply with project specification, we are able to customize desk to meet the desired requirements. Please contact ABB Control Room Solutions for support.

The Control Room Solution offering is being expanded due to our acquisition of CGM, a company that specializes in control room design and products.

Some products will remain visible in the Wizard for configuration purposes. During a transition period we kindly request you to use e-mail for orders and requests. The offering is available as hardware only, in a separate price book named Control room solutions.

Please send all questions related to control room solutions to SE-cgm-info@abb.com and your orders to SE-cgm-order@abb.com

Operations

Operator Workplaces

Operator Workplaces	Article no.	
<p>Operator Workplace – Additional Client 6.1 Includes one local or remote operator workplace, Excel based reporting aspects, Microsoft Excel is NOT included, use of up to 2 screens is included. The total quantity of Operator Workplaces, Large Operator Workplaces and Engineering Workplaces – must not exceed 80.</p>	3BSE088783R1	
<p>Large Operator Workplace Client 6.1 Includes one local or remote Operator Workplace, with the possibility to use more than 2 screens and up to 4 screens and Desktop with higher resolution than 1920*1024. The total quantity of Operator Workplaces, Large Operator Workplaces and Engineering Workplaces – must not exceed 80.</p>	3BSE088784R1	

Extended Operator Workplaces	Article no.	
<p>The EOW specific hardware is during a transition period not available for ordering through BOL.</p> <p>Information and order of EOW hardware specific setup and configuration should be sent to ABB-request@cgm.se</p>		
<p>EOW-2 Workplace License 6.1 Includes the Software licenses for an Extended operator workplace size 2, the following features are included: 2 Operator Workplace, 1 Large workplace, 1 Video Input channel, 3 Video Clients.</p>	3BSE088785R1	
<p>EOW-3 Workplace License 6.1 Includes the Software licenses for an Extended operator workplace size 3, the following features are included: 3 Large workplace, 1 Video Input channel, 3 Video Clients.</p>	3BSE088786R1	

Extended Operations	Article no.	
<p>Alarm Operations, < 2000 Tags 6.1 Alarm Grouping, Alarm Shelving and Basic Alarm Analysis. Alarm Help aspects.</p>	3BSE088788R1	
<p>Alarm Operations, < 5000 Tags 6.1 Alarm Grouping, Alarm Shelving and Basic Alarm Analysis. Alarm Help aspects.</p>	3BSE088789R1	
<p>Alarm Operations, >= 5000 Tags 6.1 Alarm Grouping, Alarm Shelving and Basic Alarm Analysis. Alarm Help aspects.</p>	3BSE088790R1	



Operations

Extended Operations

Extended Operations	Article no.
Alarm History and Reports, < 2000 Tags 6.1 Long term Alarm storage and analyze, Alarm system KPI reports, web and e-mail distribution of reports.	3BSE088791R1
Alarm History and Reports, < 5000 Tags 6.1 Long term Alarm storage and analyze, Alarm system KPI reports, web and e-mail distribution of reports.	3BSE088792R1
Alarm History and Reports, >= 5000 Tags 6.1 Long term Alarm storage and analyze, Alarm system KPI reports, web and e-mail distribution of reports.	3BSE088793R1
Symbol Factory for Process Graphics 2 6.1 Support for Symbol Factory graphics items in graphics displays.	3BSE08794R1

Operations

Public Addressing

Public Addressing	Article no.
Public Addressing output channel 6.1 One output channel with one language. The channel can convert alarms in alarmlists and predefined text messages to sound. The sound content can be configured differently for each output channel.	3BSE088795R1
Public Addressing additional language 6.1 One additional language for all channels.	3BSE088796R1

02

Operations

Live Video System

Live Video System	Article no.
Video Input Channel 1-10 6.1 Includes one software license needed to receive an IP addressed video stream to the video server. Article used to buy stream 1-1	3BSE088797R1
Video Input Channel 11-25 6.1 Includes one software license needed to receive an IP addressed video stream to the video server. Article used to buy stream 11-25	3BSE088798R1
Video Input Channel 26-50 6.1 Includes one software license needed to receive an IP addressed video stream to the video server. Article used to buy stream 26-50	3BSE088799R1
Video Input Channel 51 - 500 6.1 Includes one software license needed to receive an IP addressed video stream to the video server. Article used to buy stream 51-500	3BSE088800R1
Video View Client 6.1 One concurrent client for viewing recorded or live video source. Each client must have compatible video codec software installed.	3BSE088801R1

Production Management

Batch Management

Batch Management	Article no.	
Batch Base System 6.1 Provides the basic server functionality for batch management. The batch server includes 10 Batch Equipment. 1 Batch client included.	3BSE088802R1	
10 Additional Batch Equipment 6.1 The number of batch equipment instances includes each piece of equipment configured in Batch Management including both Units and Shared Equipment Modules.	3BSE088803R1	
100 Additional Batch Equipment 6.1 The number of batch equipment instances includes each piece of equipment configured in Batch Management including both Units and Shared Equipment Modules.	3BSE088804R1	
Batch Management Full Client 6.1 This Client feature provides access to Batch Management functions. The Client feature is based upon concurrent users, not physical workstation installation. Including SL and SQL server licenses.	3BSE088805R1	
Redundant Batch Server Option 6.1 Provides redundancy for the basic server functionality for Batch Management.	3BSE088806R1	
Batch Advanced Phase Templates 6.1 This feature provides access to the Batch Advanced templates control modules for phases, units and shared equipment modules. For use with AC 800M controllers. Batch Phase Control library option, includes 2000 Advanced Phases. Also includes Batch Unit Diagrams.	3BSE088807R1	
Batch Schedule Interface 6.1 Webservice interface to batch scheduling and equipment status. This feature is used to interface Batch Management to external applications such as schedulers and ERP systems.	3BSE088808R1	
Simple Batch Parameter Management 6.1 Batch spreadsheet recipe scheduling tool for desktop PC interface to Batch Management using Excel. (Not required when Batch Schedule Interface is ordered)	3BSE088809R1	

Engineering

Standard Engineering Tools

Standard Engineering Tools	Article no.	
Engineering Workplace – Additional Client 6.1 Includes Control Configuration for AC 800M, Bulk Data Handling, Graphic Configuration, Document Manager, Parameter Manager, I/O allocation function and Script Manager Professional. (one client is included with the Base system)	3BSE088810R1	
Engineering Workplace with Application Change Management – Client 6.1 Includes one Engineering Workplace and license for Application Change Management (ACM).	3BSE088811R1	
Engineering Workplace with LEG 6.1 Includes one Engineering Workplace and license for Load Evaluate Go (LEG).	3BSE088812R1	
Advanced Engineering Workplace – Client 6.1 Includes one Engineering Workplace and license for Application Change Management (ACM) and Load Evaluate Go (LEG).	3BSE088813R1	
SoftController 6.1 To be used with the programming tool Control Builder M. This product is to be used as a test tool only.	3BSE088814R1	

Engineering

Professional Engineering Tools

Professional Engineering Tools	Article no.	
Reuse Assistant 6.1 Wizard help for selection of reusable solutions.	3BSE088815R1	
Process Engineering Tool Integration – Base for INtools 6.1 Process Engineering Tool Integration (PETI). Supports synchronization of properties between INtools objects and existing 800xA objects and property map definition changes. New 800xA object creation is NOT supported.	3BSE088816R1	
Process Engineering Tool Integration – New Object Creation 6.1 Process Engineering Tool Integration (PETI) support for new 800xA object creation.	3BSE088817R1	

Information Management

Smart Client Workplaces	Article no.	
<p>License for one smart client workplace for access to system information from the office network.</p> <p>Includes: View Process Graphics 2 displays, Trend displays, Build/view business graphics, historic data, alarm & events analyze (H & AE analyze requires IM)</p> <p>Software media can be downloaded from ABB Library or MyABB/MyControlSystem.</p>		
Smart Client Workplace - Client 1-10 6.1	3BSE088818R1	
Smart Client Workplace - Client 11-50 6.1	3BSE088819R1	
Smart Client Workplace - Client 51-100 6.1	3BSE088820R1	

Information Management

System 800xA History

800xA History Signals – Logs	Article no.	
<p>History signals capable of storing actual and historic values retrieved from 800xA, Heritage ABB DCS systems and OPC sources. The signals include logging, trending, calculations, Alarm and Events, and archiving. A signal is any numeric (Boolean, Integer or Real) data stored in the 800xA History Server.</p>		
800xA History signals – 100 logs 6.1	3BSE088821R1	
800xA History signals – 1,000 logs 6.1	3BSE088822R1	
800xA History Signals – 15,000 logs 6.1	3BSE088823R1	

800xA Dual History Signals – Logs	Article no.	
<p>History signals for parallel logging in two history servers. Each signal includes logging, trending, calculations and archiving for parallel logging in two history servers.</p> <p>A signal is any numeric (Boolean, Integer or Real) data stored in the 800xA History Server. The number of dual history signals should match the number of history signals that should be logged in two servers.</p>		
800xA Dual history signals – 100 logs 6.1	3BSE088824R1	
800xA Dual History Signals – 1,000 logs 6.1	3BSE088825R1	
800xA Dual History Signals – 15,000 logs 6.1	3BSE088826R1	

Data access to 800xA History Signals	Article no.	
<p>External access to History data via OPC and ODBC connectivity. Access to both the current and the historical data from 800xA History.</p> <p>(Same size as total number of 800xA History Signals).</p>		
800xA History Data Access – 100 logs 6.1	3BSE088827R1	
800xA History Data Access – 1,000 logs 6.1	3BSE088828R1	
800xA History Data Access – 15,000 logs 6.1	3BSE088829R1	

Information Manager

IM Historian Server

IM Historian Server		Article no.
IM Historian Server 6.1	Logging of signals for Operator trends is included in the core system for up to three months. Logging for a longer time period, archiving to external media like DVD, discs or web based Historian tools require Historian server. 500 logs are included.	3BSE088830R1
History Logs		Article no.
	Each signal to be logged counts as one log.	
	100 History Logs 6.1	3BSE088831R1
	1,000 History Logs 6.1	3BSE088832R1
	15,000 History Logs 6.1	3BSE088833R1
Dual History Logs		Article no.
	Each signal to be logged counts as one log, for parallel logging in two history servers. (Two Basic Historian Servers are required).	
	100 Dual History Logs 6.1	3BSE088834R1
	1,000 Dual History Logs 6.1	3BSE088835R1
	15,000 Dual History Logs 6.1	3BSE088836R1
Consolidated History Logs		Article no.
	Each signal to be logged counts as one log, for consolidated logs collect data from multiple History Servers and store it in a single location. This provides a common history repository for viewing and reporting.	
	100 Consolidated History Logs 6.1	3BSE088837R1
	1,000 Consolidated History Logs 6.1	3BSE088838R1
	15,000 Consolidated History Logs 6.1	3BSE088839R1

Information Manager

IM Historian

Historian Display and Reporting Options	Article no.	
<p>Display Builder for MDI – Additional Client 6.1 Provides the ability to create Multi-Display Interface (MDI) information displays for desktop applications.</p>	3BSE088840R1	
<p>Multi-Display Interface (MDI) – Additional Client 6.1 Provides the ability to view Multi-Display Interface (MDI) information displays on any PC Desktop (max 64 per server)</p>	3BSE088841R1	
<p>Desktop Trends – Additional Client 6.1 Provides trend viewing for desktop applications. Includes web enabled trend display for long and short term history and stock ticker like viewer. (Max 64 per Server)</p>	3BSE088842R1	

Historian Data Access Options	Article no.	
<p>Excel Data Access 6.1 To access historical data through SQL from third party applications. Used to access historical data in Excel from non-800xA PC's. For 800xA Client PC's Excel Data Access is included. (Max 64 per Server)</p>	3BSE088843R1	
<p>ODBC Historic Server 6.1 Open Database Connection (ODBC) server which is needed for applications e.g. Batch Report that utilize commercial third party reporting tools.</p> <p>It includes 3rd party code (one per server).</p> <p>ODBC Clients are purchased separately from the ODBC server.</p>	3BSE088844R1	
<p>ODBC Client Connection 6.1 Open Database Connection (ODBC) client which is needed for applications e.g. Batch Report that utilize commercial third party reporting tools.</p> <p>The number of client connections required is based on whether the applications utilize the connection directly or indirectly. If the connection is made indirectly (using Oracle), then the client connection requires only one. If the client connections are direct, then the number of clients should equal the number of concurrent users. ODBC Clients are purchased separately from the ODBC server (max 10 per ODBC server).</p>	3BSE088845R1	

Control- and Communication Interface Software Licenses

Control Software Licenses

Control Software Licenses	Article no.	
PM851 SW License 800xA 6.1 PM851K01/PM851AK01 Processor Unit License only.	3BSE088846R1	
PM856 SW License 800xA 6.1 PM856K01/PM856AK01 Processor Unit License only.	3BSE088847R1	
PM857 SW License 800xA 6.1 PM857K01 Processor Unit License only.	3BSE089965R1	
PM857 Red. SW License 800xA 6.1 PM857K02 Redundant Processor Unit License only.	3BSE089966R1	
PM858 SW License 800xA 6.1 PM858K01 Processor Unit License only.	3BSE088848R1	
PM858 Red. SW License 800xA 6.1 PM858K02 Redundant Processor Unit License only.	3BSE088849R1	
PM860 SW License 800xA 6.1 PM860K01/PM860AK01 Processor Unit License only.	3BSE088850R1	
PM861 SW License 800xA 6.1 PM861K01/PM861AK01 Processor Unit License only.	3BSE088851R1	
PM861 Red. SW License 800xA 6.1 PM861K02/PM861AK02 Redundant Processor Unit License only.	3BSE088852R1	
PM862 SW License 800xA 6.1 PM862K01 Processor Unit License only.	3BSE088853R1	
PM862 Red. SW License 800xA 6.1 PM862K02 Redundant Processor Unit License only.	3BSE088854R1	
PM863 SW License 800xA 6.1 PM863K01 Processor Unit License only.	3BSE089963R1	
PM863 Red. SW License 800xA 6.1 PM863K02 Redundant Processor Unit License only.	3BSE089964R1	
PM864 SW License 800xA 6.1 PM864K01/PM864AK01 Processor Unit License only.	3BSE088855R1	
PM864 Red. SW License 800xA 6.1 PM864K01/PM864AK02 Redundant Processor Unit License only.	3BSE088856R1	
PM865 SW License 800xA 6.1 PM865K01 Processor Unit License only.	3BSE088857R1	
PM865 Red. SW License 800xA 6.1 PM865K02 Redundant Processor Unit License only.	3BSE088858R1	
PM866 SW license 800xA 6.1 PM866K01/PM866AK01 Processor Unit License only.	3BSE088859R1	
PM866 Red. SW License 800xA 6.1 PM866K02/PM866AK02 Redundant Processor Unit License only.	3BSE088860R1	
PM867 SW License 800xA 6.1 PM867K01 Processor Unit License only.	3BSE088861R1	
PM867 Red. SW License 800xA 6.1 PM867K02 Redundant Processor Unit License only.	3BSE088862R1	
PM891 SW License 800xA 6.1 PM891K01 Processor Unit License only.	3BSE088863R1	
PM891 Red. SW License 800xA 6.1 PM891K02 Redundant Processor Unit License only.	3BSE088864R1	
SM811 Safety CPU SW License 800xA 6.1 SM811K01 Safety CPU module kit License only.	3BSE088865R1	
SM812 Safety CPU SW license 800xA 6.1 SM812K01 Safety CPU module kit License only.	3BSE088866R1	

Control- and Communication Interface Software Licenses

Communication Interface Software Licenses

Communication Interface Software Licenses	Article no.	
CI853 Dual RS232 SW License 800xA 6.1 CI853K01 Dual RS232-C Communication Interface License only.	3BSE088867R1	
CI854 PROFIBUS SW License 800xA 6.1 CI854K01/CI854AK01/CI854BK01 PROFIBUS DP-V1 Communication Interface License only.	3BSE088868R1	
CI855 MB 300 SW License 800xA 6.1 CI855K01 MB 300 Dual Ethernet port interface License only.	3BSE088869R1	
CI856 S100 I/O SW License 800xA 6.1 CI856K01 S100 I/O Communication Interface License only.	3BSE088870R1	
CI857 INSUM SW License 800xA 6.1 CI857K01 INSUM Ethernet Communication Interface License only.	3BSE088871R1	
CI858 DriveBus SW License 800xA 6.1 CI858K01 DriveBus Communication Interface License only.	3BSE088872R1	
CI860 FF HSE SW License 800xA 6.1 CI860K01 FOUNDATION Fieldbus HSE Communication Interface License only.	3BSE088873R1	
CI862 TRIO SW License 800xA 6.1 CI862K01 TRIO Communication Interface, G1 compliant. License only.	3BSE088874R1	
CI862 Red. TRIO SW License 800xA 6.1 CI862K02 Redundant TRIO Communication Interface, G1 Compliant. License only.	3BSE088875R1	
CI865 Satt I/O SW License 800xA 6.1 CI865K01 Satt I/O Communication Interface License only.	3BSE088876R1	
CI867 Modbus TCP SW License 800xA 6.1 CI867K01 Modbus TCP Communication Interface License only.	3BSE088877R1	
CI868 IEC 61850 SW License 800xA 6.1 CI868K01 IEC61850 Communication Interface License only.	3BSE088878R1	
CI869 AF 100 SW License 800xA 6.1 CI869K01 AF 100 Communication Interface License only.	3BSE088879R1	
CI871 PROFINET IO SW License 800xA 6.1 CI871K01 PROFINET IO Communication Interface License only.	3BSE088880R1	
CI873 Ethernet/IP SW License 800xA 6.1 CI873K01 Ethernet/IP Communication Interface License only.	3BSE088881R1	

800xA 6.1 System

Safety

Enabler for combined PA Control and Certified Safety software	Article no.	
AC 800M High Integrity and Process Control license 6.1 One fixed license feature per AC 800M controller running both non-SIL and SIL applications in the same controller.	3BSE088882R1	

800xA 6.1 System

Asset Optimization

Asset Optimization	Article no.	
100 Asset Monitors 6.1 Asset monitoring and Basic Asset Monitor Library. Each Aspect Object being monitored by one or more asset monitors counts as one.	3BSE088883R1	
1000 Asset Monitors 6.1 Asset monitoring and Basic Asset Monitor Library. Each Aspect Object being monitored by one or more asset monitors counts as one.	3BSE088884R1	
800xA Maximo Integration 6.1 Enables integration into Maximo for work order management. Application Engineering available through ConsultIT.	3BSE088885R1	
800xA SAP / Plant Maintenance Integration 6.1 Enables integration into SAP for work order management. Application Engineering available through ConsultIT.	3BSE088886R1	

Asset Optimization

Asset Monitors

Asset Monitors	Article no.
Generic Heat Exchanger Asset Monitor 6.1 It monitors the performance against standard operating parameters independent of type of heat exchanger.	3BSE088887R1
Shell/Tube Heat Exchanger Asset Monitor 6.1 It monitors the performance against standard operating parameters based on the size of shell and tube heat exchanger.	3BSE088888R1
Advanced Harmony System Monitoring 6.1 Enables Harmony Control Network monitors for diagnostic monitoring, reporting, and analysis	3BSE088889R1
100 Control Loop Asset Monitors 6.1 Each Control Loop Asset Monitor monitors and assesses the performance of a control loop in real-time and report significant problems related to the control loop and final control element.	3BSE088890R1
300 Control Loop Asset Monitors 6.1 Each Control Loop Asset Monitor monitors and assesses the performance of a control loop in real-time and report significant problems related to the control loop and final control element.	3BSE088891R1
500 Control Loop Asset Monitors 6.1 Each Control Loop Asset Monitor monitors and assesses the performance of a control loop in real-time and report significant problems related to the control loop and final control element.	3BSE088892R1
PNSM, < 2000 Tags 6.1 PC, Network and Software Monitoring (PNSM) enables availability monitoring of IT assets, like servers and workstations, network and software components. This option is for systems with less than 2000 Tags.	3BSE089950R1
PNSM, <5000 Tags 6.1 PC, Network and Software Monitoring (PNSM) enables availability monitoring of IT assets, like servers and workstations, network and software components. This option is for systems with 2000 Tags or more, but with less than 5000 Tags.	3BSE089951R1
PNSM, >=5000 Tags 6.1 PC, Network and Software Monitoring (PNSM) enables availability monitoring of IT assets, like servers and workstations, network and software components. This option is for systems with 5000 Tags or more.	3BSE089952R1

800xA 6.1 System

Device Management & Fieldbuses

Device Management HART	Article no.
For HART devices to be accessed using Device Type Manager (DTM's) within System 800xA. Includes HART Device Library with generic and specific HART Device Aspect Objects incl. DTM's, I/O DTM for S800 and S900, HART Instruments Asset Monitor Library and OPC Server. Each HART device aspect object accessed with DTM counts as one. (Max 1 000 per Connectivity Server when OPC Communication is used. For details refer to System Guide)	
100 HART Device Aspect Objects 6.1	3BSE088894R1
1,000 HART Device Aspect Objects 6.1	3BSE088895R1
10,000 HART Device Aspect Objects 6.1	3BSE088896R1
HART Multiplexer Connect 6.1 Enables HART Device Integration to connect to HART devices using HART Multiplexers.	3BSE088897R1

800xA 6.1 System

Device Management & Fieldbuses

Device Management FOUNDATION Fieldbus	Article no.	
For FOUNDATION Fieldbus (FF) devices to be accessed using Fieldbus Builder FF within System 800xA. Includes FF Device Library with FF Device Aspect Objects, FF Instruments Asset Monitor Library and OPC Server. Each FF device aspect object counts as one. (Max 1000 per Connectivity Server. For details refer to System Guide.)		
100 FF Device Aspect Objects 6.1	3BSE088898R1	
1,000 FF Device Aspect Objects 6.1	3BSE088899R1	
10,000 FF Device Aspect Objects 6.1	3BSE088900R1	
Device Management PROFIBUS	Article no.	
For PROFIBUS DP/PA devices to be accessed using Device Type Manager (DTM's) within System 800xA. Includes PROFIBUS Device Library with specific PROFIBUS Device Aspect Objects incl. DTM's, I/O DTM for S800 and S900, and PROFIBUS Instruments Asset Monitor Library. Each PROFIBUS device aspect object accessed with DTM counts as one. (Max 2500 per Connectivity Server if OPC communication is used. For details refer to System Guide.)		
100 PROFIBUS Device Aspect Objects 6.1	3BSE088901R1	
1,000 PROFIBUS Device Aspect Objects 6.1	3BSE088902R1	
10,000 PROFIBUS Device Aspect Objects 6.1	3BSE088903R1	
IEC 61850 Connect	Article no.	
For operation clients to access data and alarm and event values from Intelligent Electronic Devices (IEDs) according to IEC 61850 within System 800xA. For Redundant IEC 61850 Connect servers, it is only necessary to purchase the "IEC 61850 Redundant Devices" licenses, according to the number of devices connected to the System. OBS: This package includes license rights to Parallel Redundancy Protocol (PRP) Duo Driver software. A separate license file must be requested separately via email to pact.operationscenter@se.abb.com . In order to develop the IEC 61850 configuration in projects, for example creating and editing Substation Configuration Description (SCD) files, one must purchase the IEC 61850 Engineering Tool. The IEC 61850 Engineering Tool is licensed separately from System 800xA licenses, and one license can be used in several projects. Please refer to Ref. Doc 2PAA113852 for more details on how to purchase and license it. For order of IEC 61850 related products, local organizations must comply with the Demands on the Purchaser to secure successful sales of IEC 61850 with System 800xA. Ref doc, 3BSE058798.		
10 IEC 61850 Non-Redundant Devices Allows operation clients to access data and alarm and event values from Intelligent Electronic Devices (IEDs) according to IEC 61850, through Non-Redundant IEC 61850 Connect server. Each IED instance created in System 800xA counts as one. Package includes license to Parallel Redundancy Protocol (PRP) Duo Driver software for connecting with redundant-network IEDs through PRP protocol.	3BSE089953R1	
100 IEC 61850 Non-Redundant Devices Allows operation clients to access data and alarm and event values from Intelligent Electronic Devices (IEDs) according to IEC 61850, through Non-Redundant IEC 61850 Connect server. Each IED instance created in System 800xA counts as one. Package includes license to Parallel Redundancy Protocol (PRP) Duo Driver software for connecting with redundant-network IEDs through PRP protocol.	3BSE089954R1	

IEC 61850 Redundant Connect	Article no.	
<p>10 IEC 61850 Redundant Devices Allows operation clients to access data and alarm and event values from Intelligent Electronic Devices (IEDs) according to IEC 61850, through Redundant IEC 61850 Connect server. Each IED instance created in System 800xA counts as one. Package includes license to Parallel Redundancy Protocol (PRP) Duo Driver software for connecting with redundant-network IEDs through PRP protocol.</p>	3BSE089955R1	
<p>100 IEC 61850 Redundant Devices Allows operation clients to access data and alarm and event values from Intelligent Electronic Devices (IEDs) according to IEC 61850, through Redundant IEC 61850 Connect server. Each IED instance created in System 800xA counts as one. Package includes license to Parallel Redundancy Protocol (PRP) Duo Driver software for connecting with redundant-network IEDs through PRP protocol.</p>	3BSE089956R1	

800xA 6.1 System Libraries

Libraries	Article no.	
<p>INFI90 Function Code Library for AC 800M 6.1 Control functions, faceplates and graphics elements that makes it easier to create functionality that has earlier been configured in an INFI90 system. Requires separate media.</p>	3BSE088906R1	
<p>MOD 300 CCF Library for AC 800M 6.1 Control functions, faceplates and graphics elements that makes it easier to create functionality that has earlier been configured in a MOD300 system. Requires separate media.</p>	3BSE088907R1	
<p>TCP Communication Library License 6.1 Control functions to create TCP based communication protocols in the AC800M controller. One licence is needed for each controller using the library.</p>	3BSE088908R1	
<p>UDP Communication Library License 6.1 Control functions to create UDP based communication protocols in the AC800M controller. One licence is needed for each controller using the library.</p>	3BSE088909R1	
<p>PM857 Burner Management Library License 6.1 Control functions for burner management applications. One license is needed for each PM857 using the library.</p>	3BSE089970R1	
<p>PM863 Burner Management Library License 6.1 Control functions for burner management applications. One license is needed for each PM863 using the library.</p>	3BSE089969R1	
<p>PM865 Burner Management Library License 6.1 Control functions for burner management applications. One license is needed for each PM865 using the library.</p>	3BSE088910R1	
<p>PM867 Burner Management Library License 6.1 Control functions for burner management applications. One license is needed for each PM867 using the library.</p>	3BSE088911R1	

800xA

Process Industries Application Libraries

Process Industries Application Libraries

The Process Industries Application Libraries (PIAL) in this book include Process Control Device Library (PCDL), Process Control Equipment Library (PCEL) and ProBase Library. One valid license is required per 800xA system. User documentation is provided electronically with the product media. The licenses support use with System 800xA. These licenses entitle license holders to use the library in one system, meaning one Aspect Server. Please refer to System Guide Ordering and Licensing for more information.

PIAL Media

PIAL Media

Media for this product can be downloaded from ABB Library and MyABB/MyControlSystem.

Process Control Device Library

Process Control Device Library

The 800xA PC Device Library provides device-level objects. The PCDeviceLib is a customized library for the process industry. It builds upon the 800xA - AC800M library to provide additional functionality and engineering efficiency. Benefits include minimizing the initial learning curve for the ABB Ability™ System 800xA Extended Automation and to minimize the engineering effort.

The PCDevice Library contains an extensive list of objects, but it is licensed only by the number of Control Elements used. Control Elements are the Valves, Motors and PID Loops in a system.

The following PCDevice library control modules are categorized as Control Elements – Valve, ValveMan, MotorOnOff, MotorOnOffAdv, Motor2Speed, MotorVarSpeed, ControllerPIDLoop, ControlValvePneumatic, ControlValveElectric, ChokeValve, MotorOnOffCore, Motor2SpeedCore and MotorVarSpeedCore.

Process Industries Application Libraries

Process Control Device Library Licenses	Article no.
Base Process Control Device Library 6.1 The PCDevice Library comes with all PCDevice library objects but only the 13 objects listed above are counted as Control Elements. To arrive at the correct number of Control Elements to purchase, count the number of Valve, Motor and ControllerPIDLoop objects associated with the project. Including 125 Control Elements.	3BSE088912R1

Additional Control Device Library Licenses

Additional Control Device Library Licenses	Article no.
Additional 125 Control Elements for PCDL 6.1 Additional 125 Control Elements for Process Control Device Library (PCDL).	3BSE088913R1

PCDL Application Engineering

PCDL Application Engineering	Article no.
<p>PCDL License for Application Engineering 6.1 This license is intended to use for Application Engineering purpose only. A maximum of 2500 Control Elements will be issued as a part of the license. For production system, appropriate quantity of Control Elements license must be purchased separately.</p>	3BSE088914R1
<p>PCDL Additional License for Application Engineering 6.1 Each additional license comes with 2500 control elements license.</p>	3BSE088915R1

Process Control Equipment Library

Process Control Equipment Library
<p>Process Control Equipment Library (PCEquipmentLib) is a comprehensive library of Equipment Module templates, and toolkit components for industrial IT Extended Automation System 800xA.</p> <p>PCEquipmentLib is designed to optimize the specification and building of ANSI/ISA-88.01-1995 style Equipment Modules and customized Process Units. Designed to "plug and produce" with standard PCDeviceLib control objects, PCEquipmentLib shares common terminology, engineering principles, and naming conventions to make engineering consistent and easy. It is a requirement to use a compatible version of PCDevice Library in conjunction with PCEquipment Library. Refer to PCEquipment Library release notes for appropriate version information.</p> <p>The PCEquipment Library contains an extensive list of pre-engineered and validated objects like Unit template and Standard Phases, equipment modules, Quality Monitor, pcc supervision, EqTimer, Prompts/ PromptsAlarmOwner etc. The PCEquipment Library also contains pre-engineered facility automation solution objects.</p>

Process Control Equipment Library Licenses

Process Control Equipment Library Licenses	Article no.
<p>Base PC Equipment Lib. - Batch 6.1 This license is for working with up to 125 PCDevice Lib Control Elements with Batch Management.</p> <p>This license shall allow using any number of PCEL Batch Unit type with Standard Phases.</p>	3BSE088916R1
<p>Base PC Equipment Lib. - Non-Batch 6.1 This license is for working with up to 125 PCDevice Lib Control Elements without Batch Management. This license shall allow using any number of PCEL Equipment Module (EM) types with Device Summary and ModeControl.</p>	3BSE088917R1

PIAL Media

Additional Control Equipment Library Licenses

Additional Control Equipment Library Licenses
<p>It is a requirement to use a compatible version of PCDevice Library in conjunction with PCEquipment Library. Refer to PCEquipment Library release notes for appropriate version information. Additional expansion licenses can be purchased. When ordering additional licenses, the original quantity and the license information must be included with the expansion order.</p>

Additional Control Equipment Library Licenses	Article no.
<p>Add. PC Equipment Lib. -Batch 6.1 Each Expansion license is for working with up to 125 PCDevice Lib Control Elements with Batch Management.</p>	3BSE088918R1
<p>Add. PC Equipment Lib. - non Batch 6.1 Each Expansion license is for working with up to 125 PCDevice Lib Control Elements without Batc Management.</p>	3BSE088919R1

PCEL Application Engineering

PCEL Application Engineering	Article no.
<p>PCEL License for Application Engineering 6.1 This license is intended to use for Application Engineering purpose only. A maximum of 20 PCEL With Batch Management license quantity will be issued as a part of this license, which can be used with both Batch and Non-Batch version of PC EquipmentLib.</p>	3BSE088920R1
<p>PCEL Additional License for Application Engineering 6.1 Each additional license comes with 20 PCEL license, which can be used with both Batch and Non-Batch version of PCEquipmentLib.</p>	3BSE088921R1

ProBase

ProBase
<p>ProBase is a set of System 800xA libraries with industry specific functionality targeting liquid process handling or other applications where routing, storage of material, CIP, etc. are a major concern in the application. Example industries are food & beverage, chemical, pharmaceuticals, tank farms, etc.</p>

ProBase Licenses	Article no.
ProBase licensing is based on type and number of controllers executing ProBase.	
ProBase 6.1 PM858 SW Lic. 6.1	3BSE089957R1
ProBase 6.1 PM861 SW Lic. 6.1	3BSE088924R1
ProBase 6.1 PM862 SW Lic. 6.1	3BSE089958R1
ProBase 6.1 PM864 SW Lic. 6.1	3BSE088925R1
ProBase 6.1 PM866 SW Lic. 6.1	3BSE088927R1
ProBase 6.1 PM891 SW Lic. 6.1	3BSE088928R1

Localization

National Language Support (NLS) is intended for the localization of the operator interface to the desired language. NLS contains a set of functions that are harmonized with the Windows regional settings to enable a multilingual environment for the System 800xA.

The System 800xA supports translations, mainly the operator interface and the operator manuals as shown in the Table 3 and Table 4. The translation, or System 800xA Language Package, is implemented as a system extension and is possible to install without stopping the system.

The NLS Localization Guide describes what and how localization can be performed by a project with or without an installed Language Package. The English version of the Windows operating system is required. The System 800xA Language Packages can be downloaded free of charge from ABB Library.

It is always advisable to download full Language Package from ABB Library or advised, for each new installation to secure the latest updates for language packages.

Table 3. Supported Language Packages for Functional Areas

Language Packages	Functional Areas							
	Base System	*Safety	SMS & eMailing	**Asset Optimization	FOUNDATION FIELDBUS	Batch Management	*** Information Management	SFC Viewer
English (default)	Yes	Yes	Yes	Yes	Yes	Yes	Yes	Yes
Arabic	Yes	Yes						Yes
Chinese	Yes	Yes		Yes	Yes	Yes	Yes	Yes
French	Yes	Yes	Yes				Yes	Yes
German	Yes	Yes	Yes	Yes		Yes	Yes	Yes
Russian	Yes	Yes					Yes	Yes
Spanish	Yes	Yes	Yes				Yes	Yes
Swedish	Yes	Yes	Yes			Yes	Yes	Yes

* Confirmation and authentication operation dialog Window for SIL-2 high integrity controller.

** Only system messages

*** Storage of messages in local language

Table 4. Supported Language Packages for Connectivity

Language Packages	Connectivity			
	800xA for AC 800M	800xA for Advant Master	PLC Connect	800xA for Melody
English (default)	Yes	Yes	Yes	Yes
Arabic	Yes			
Chinese	Yes	Yes	Yes	
French	Yes	Yes		
German	Yes	Yes		Yes
Russian	Yes	Yes		
Spanish	Yes			
Swedish	Yes	Yes		

AC 800M Processor Units

CPU Modules

Several CPU modules are available that vary in terms of processing power, memory size, and redundancy support. Each CPU module is equipped with built in Ethernet port(s) for communication with other controllers and for interaction with operators, engineers, managers, and higher level applications. These ports can be configured for redundancy for those cases where availability is of paramount importance. It is also equipped with two RS-232C ports that can be used for point-to-point communication with programming/debugging tools and with third-party systems and devices.

The SIL3-rated and IEC61508-certified, AC 800HI controller supports running both process control and safety application, in the same machine.

The AC 800M controller can be configured with 800xA control builder. When configured with the 800xA control builder AC 800M becomes a tightly integrated part of the System 800xA.

Communication & I/O Modules

To each CPU module, a number of communication and I/O modules can be added, for example:

- Additional RS-232C ports
- PROFIBUS DP, PROFINET IO
- Foundation Fieldbus HSE/H1
- DeviceNet
- IEC 61850
- Ethernet IP
- MasterBus 300
- MODBUS TCP
- S100 I/O
- S800 I/O
- S800L I/O
- S900 I/O



AC 800M PM891 controller



AC 800M controller



AC 800M High Integrity controller

AC 800M Controllers selection guide

Features / CPUs	PM851A	PM856A	PM857	PM858	PM860A	PM862	PM863
Processor Unit	PM851AK01 incl: 1 PM851A CPU and required optional items	PM856AK01 incl: 1 PM856A CPU and required optional items	PM857K01 incl: 1 PM857 CPU and required optional items PM857K02 incl: 2 PM857K01	PM858K01 incl: 1 PM858 CPU and required optional items PM858K02 incl: 2 PM858K01	PM860AK01 incl: 1 PM860A CPU and required optional items	PM862K01 incl: 1 PM862 CPU and required optional items. PM862K02 incl: 2 PM862K01	PM863K01 incl: 1 PM863 CPU and required optional items PM863K02 incl: 2 PM863K01
Optional items (partly included in Processor Units, see Price List)	TP830 Baseplate, TP850 CEX-bus term., TK850 CEX-bus cable, TB807, Modulebus term, Battery RAM backup, TB852/TB853 RCU-link term, TB851/TB855/TB856 RCU-link cable, SB822 External Battery Unit, TK212A Tool cable, TC562 Short Distance Modem, TK853V020 Modem cable, BC810K02, BC820K02, CEX-bus Interconnection unit; TK851V010 Connection cable, SD831/SD832/SD833, SD853/SD854 Power Supply, SS832 Voting Unit, Mains Breaker Kit, SM811 Supervisory Module and SM812 Supervisory Module.						
High Integrity Controller	No	No	Yes	No	No	No	Yes
Clock frequency	24 MHz	24 MHz	96 Mhz	33 MHz	48 MHz	67 MHz	96 Mhz
Memory (RAM)	8 MB	8 MB	32 MB	16 MB	8 MB	32 MB	32 MB
From 5.1 FP4	12 MB	16 MB			16 MB		
RAM available for application	2.282 MB	2.282 MB	22.184 MB	7.147 MB	2.282 MB	23.521 MB	22.184 MB
From 5.1 FP4	6.253 MB	10.337 MB			10.346 MB		
Processor type	MPC860	MPC860	MPC866	MPC866	MPC860	MPC866	MPC866
Flash memory for storage of application and data	Yes	Yes	No	Yes	Yes	Yes	No
CPU redundancy support	No	No	Yes	Yes	No	Yes	Yes
Switch over time in red. conf.	-	-	Max 10 ms	Max 10 ms	-	Max 10 ms	Max 10 ms
Performance, 1000 boolean operations (a:=b and c)	0.46 ms	0.46 ms	0.17 ms	0.36 ms	0.23 ms	0.18 ms	0.17 ms
No. controllers per control projects	32						
No. of applications per control project	1024						
No. of applications per controller	32						
No. of programs per application	64						
No. of tasks per controller	32						
Number of different cycle times	32						
Cycle time per application programs	Down to 1 ms (HI Integrity controllers 10 ms)						
Flash PROM for firmware storage	2 MB	2 MB	18 MB	4 MB	2 MB	4 MB	18 MB
Power supply	24 V DC (19.2-30 V DC) max 5 % ripple acc. to IEC 61131-2						
Power consumption +24 V	typ/max 180/300 mA	typ/max 180/300 mA	typ/max 210/360 mA	typ/max 210/360 mA	typ/max 180/300 mA	typ/max 210/360 mA	typ/max 210/360 mA
Power dissipation typ.	4.32 W	4.32 W	5.1 W	5.1 W	4.32 W	5.1 W	5.1 W
Power Reservoir	Internal 5 ms power reservoir, sufficient for the CPU to make a controlled power down						
Power supply connector	Detachable 4-pole screw terminal block						
Redundant power supply status inputs	Yes: 2 inputs designated SA, SB (Max 30 V, high level >15 V, low level < 8 V)						
Built-in back-up battery	Type: Lithium, 3.6 V, 0.95 Ah, size 1/2 AA, 0.3 g Lithium content						
Real-time clock stability	100 ppm (approx. 1 h/year)						
Clock synchronization	1 ms between AC 800M controllers by CNCP protocol						
Comm. modules on CEX bus	1	12	12	12	12	12	12

Features / CPUs	PM851A	PM856A	PM857	PM858	PM860A	PM862	PM863
Supply current on CEX bus	Supply current: Max 24 V - 2.4 A (fuse 3.15 A fast, PM891 has an embedded auto fuse)						
I/O clusters on Modulebus with non-redundant CPU	1 el. + 1 opt.	1 el. + 7 opt.	1 el. + 7 opt.	1 el. + 7 opt.	1 el. + 7 opt.	1 el. + 7 opt.	1 el. + 7 opt.
I/O clusters on Modulebus with redundant CPU	NA	NA	0 el. + 7 opt.	7 optical	NA	7 optical	0 el. + 7 opt.
I/O capacity on Modulebus with non-redundant/redundant CPU	Max 24/NA I/O modules	Max 96/NA I/O modules	Max 96/84 I/O modules and max 128 I/O channels	Max 96/84 I/O modules	Max 96/NA I/O modules	Max 96/84 I/O modules	Max 96/84 I/O modules
Modulebus scan rate	0 - 100 ms (actual time depending on number of I/O modules)						
Supply current on Electrical Modulebus	Supply current: Max 24 V - 1.0 A (short circuit proof, fuse 2.0 A), Max 5 V - 1.5 A (short circuit proof)						
I/O capacity on PROFIBUS (remote I/O)	Max 99 I/O stations (max 62 redundant I/O stations), max 24 I/O modules per I/O station (max 12 redundant I/O pairs)						
Ethernet channels	1	2	2	2	2	2	2
Ethernet interface	Ethernet (IEEE 802.3), 10 Mbit/s, RJ-45, female (8-pole)						
Control Network protocol	MMS (Manufacturing Message Service) and IAC (Inter Application Communication)						
Recommended Control Network backbone	100 Mbit/s switched Ethernet						
No. of controllers on Control Network	Max 50						
RS-232C interface	2 (one general, 1 for service tool)						
RS-232C interface (COM3) (non red.conf. only)	RS-232C, 75-19 200 baud, RJ-45 female (8-pole), not opto isolated, full RTS-CTS support						
RS-232C interface (COM4) (non red.conf. only)	RS-232C, 9 600 baud, RJ-45 female (8-pole), opto isolated, no RTS-CTS support						
Temperature	<ul style="list-style-type: none"> • Operating +5 to +55 °C (+41 to +131 °F) • Storage -40 to +70 °C (-40 to +158 °F) 						
Temperature changes	3 °C/minutes according to IEC/EN 61131-2						
Altitude	2000 m according to IEC/EN 61131-2						
Pollution degree	Degree 2 according to IEC/EN 61131-2						
Corrosion protection	G3 compliant to ISA 71.04						
Vibration	10 < f < 50 Hz: 0.0375 mm amplitude, 50 < f < 150 Hz: 0.5 g acceleration, 5 < f < 500 Hz: 0.2 g acceleration						
Emitted noise	< 55 dB (A)						
Shock, no package	150 m/s ² in 11 ms, 20 g in 3 ms						
Relative humidity	5 to 95 %, non-condensing						
Isolation voltage	Type test voltage: 500 V AC (corresponding to 700 V DC)						
Environmental conditions	Industrial						
Protection class	IP20 according to EN 60529, IEC 529						
Certificates and Standards *	CE- marking: Meets EMC directive 2004/108/EC acc. to EN 61000-6-4, EN 61000-6-2 and Low Voltage Directive acc. to EN 61131-2 Electrical Safety: EN 50178, IEC 61131-2, UL 508 Hazardous location: UL 60079-15, cULus Class 1, Zone 2, AEx nA IIC T4, ExnA IIC T4Gc X RoHS compliance: EN 50581:2012 WEEE compliance: DIRECTIVE/2012/19/EU						
TÜV Approval	No	No	IEC 61508 SIL3	No	No	No	IEC 61508 SIL3
Emission	Tested according to EN 61000-6-4 EMC – Generic Emission Standard, Part 2 – Industrial Environment						
Immunity	Tested according to EN 61000-6-2 EMC – Generic Immunity Standard, Part 2 – Industrial Environment						
Dimensions	Width 119 x Height 186 x Depth 135 mm (4.7 x 7.3 x 5.3 in.)						
Weight (including base)	1100 g (2.4 lbs)	1100 g (2.4 lbs)	1200 g (2.6 lbs)	1200 g (2.6 lbs)	1100 g (2.4 lbs)	1200 g (2.6 lbs)	1200 g (2.6 lbs)

* For detailed information on each module, please visit: www.800xahardwareselector.com

AC 800M Controllers selection guide

Features / CPUs	PM865	SM811	PM866A	PM867	SM812	PM891
Processor Unit	PM865K01 incl: 1 PM865 CPU and required optional items PM865K02 incl: 2 PM865K01	SM811K01 incl: 1 SM811	PM866AK01 incl: 1 PM866A CPU and required optional items PM866AK02 incl: 2 PM866AK01	PM867K01 incl: 1 PM867 CPU and required optional items PM867K02 incl: 2 PM867K01	SM812K01 incl: 1 SM812	PM891K01 incl: 1 PM891 CPU and required optional items PM891K02 incl: 2 PM891K01
Optional items (partly included in Processor Units, see Price List)	TP830 Baseplate, TP850 CEX-bus term., TK850 CEX-bus cable, TB807, Modulebus term, Battery RAM backup, TB852/TB853 RCU-link term, TB851/TB855/TB856 RCU-link cable, SB822 External Battery Unit, TK212A Tool cable, TC562 Short Distance Modem, TK853V020 Modem cable, BC810K02, BC820K02, CEX-bus Interconnection unit; TK851V010 Connection cable, SD831/SD832/SD833, SD853/SD854 Power Supply, SS832 Voting Unit, Mains Breaker Kit, SM811 Supervisory Module and SM812 Supervisory Module.					
High Integrity Controller	Yes	Yes	No	Yes	Yes	No
Clock frequency	96 MHz	96 MHz	133 MHz	133 MHz	133 MHz	450 MHz
Memory (RAM) From 5.1 FP4	32 MB	32 MB	64 MB	64 MB	64 MB	256 MB
RAM available for application	22.184 MB	-	51.389 MB	46.559 MB	-	208.985 MB
Processor type	MPC862P	MPC862P	MPC866	MPC866	MPC866	MPC8270
Flash memory for storage of application and data	No	No	Yes	No	No	Yes
CPU redundancy support	Yes	Yes	Yes	Yes	Yes	Yes
Switch over time in red. conf.	Max 10 ms	Max 10 ms	Max 10 ms	Max 10 ms	Max 10 ms	Max 10 ms
Performance, 1000 boolean operations (a=b and c)	0.17 ms	-	0.09 ms	0.09 ms	-	0.043 ms
No. controllers per control projects	32					
No. of applications per control project	1024					
No. of applications per controller	32					
No. of programs per application	64					
No. of tasks per controller	32					
Number of different cycle times	32					
Cycle time per application programs	Down to 1 ms (HI Integrity controllers 10 ms)					
Flash PROM for firmware storage	4 MB	4 MB	4 MB	18 MB	4 MB	16 MB
Power supply	24 V DC (19.2-30 V DC) max 5 % ripple acc. to IEC 61131-2					
Power consumption +24 V (typ/max)	287/487 mA	160/250 mA	210/360 mA	210/360 mA	160/250 mA	660/750 mA
Power dissipation typ.	6.9 W	3.8 W	5.1 W	5.1 W	3.8 W	15.8 W
Power Reservoir	Internal 5 ms power reservoir, sufficient for the CPU to make a controlled power down					
Power supply connector	Detachable 4-pole screw terminal block					
Redundant power supply status inputs	Yes: 2 inputs designated SA, SB (Max 30 V, high level >15 V, low level < 8 V)					
Built-in back-up battery	Type: Lithium, 3.6 V, 0.95 Ah, size 1/2 AA, 0.3 g Lithium content				No	No
Real-time clock stability	100 ppm (approx. 1 h/year)					50 ppm
Clock synchronization	1 ms between AC 800M controllers by CNCP protocol					
Comm. modules on CEX bus	12		12		12	
Supply current on CEX bus	Supply current: Max 24 V - 2.4 A (fuse 3.15 A fast, PM891 has an embedded auto fuse)					
I/O clusters on Modulebus with non-redundant CPU	1 el. + 7 opt.		N/A	1 el. + 7 opt.	1 el. + 7 opt.	0 el. + 7 opt.
I/O clusters on Modulebus with redundant CPU	0 el. + 7 opt.		N/A	0 el. + 7 opt.	0 el. + 7 opt.	0 el. + 7 opt.

Features / CPUs	PM865	SM811	PM866A	PM867	SM812	PM891
I/O capacity on Modulebus with non-redundant/redundant CPU	Max 96/84 I/O modules	N/A	Max 96/84 I/O modules	Max 96/84 I/O modules	N/A	Max 84/84 I/O modules
Modulebus scan rate	0 - 100 ms (actual time depending on number of I/O modules), 0 - 300 for PM865 and PM867					
Supply current on Electrical Modulebus	Supply current: Max 24 V - 1.0 A (short circuit proof, fuse 2.0 A), Max 5 V - 1.5 A (short circuit proof)			24 V : max 1.0 A 5 V : max 1.5 A		Not supported
I/O capacity on PROFIBUS (remote I/O)	Max 99 I/O stations (max 62 redundant I/O stations), max 24 I/O modules per I/O station (max 12 redundant I/O pairs)					
Ethernet channels	2	N/A	2	2	N/A	2
Ethernet interface	Ethernet (IEEE 802.3), 10 Mbit/s, RJ-45, female (8-pole)					10/100 Mbit/s
Control Network protocol	MMS (Manufacturing Message Service) and IAC (Inter Application Communication)					
Recommended Control Network backbone	100 Mbit/s switched Ethernet					
No of controllers on Control Network	Max 50					
RS-232C interface	2 (one general, 1 for service tool)				N/A	1 for service tool (COM 4)
RS-232C interface (COM3) (non red.conf. only)	RS-232C, 75-19 200 baud, RJ-45 female (8-pole), not opto isolated, full RTS-CTS support				N/A	Not supported
RS-232C interface (COM4) (non red.conf. only)	RS-232C, 9 600 baud, RJ-45 female (8-pole), opto isolated, no RTS-CTS support					
Temperature	<ul style="list-style-type: none"> Operating: +5 to +55 °C (+41 to +131 °F) Storage: -40 to +70 °C (-40 to +158 °F) 					
Temperature changes	3 °C/minutes according to IEC/EN 61131-2					
Altitude	2000 m according to IEC/EN 61131-2					
Pollution degree	Degree 2 according to IEC/EN 61131-2					
Corrosion protection	G3 compliant to ISA 71.04					
Vibration	10 < f < 50 Hz: 0.0375 mm amplitude, 50 < f < 150 Hz: 0.5 g acceleration, 5 < f < 500 Hz: 0.2 g acceleration					
Emitted noise	< 55 dB (A)					
Shock, no package	150 m/s ² in 11 ms, 20 g in 3 ms					
Relative humidity	5 to 95 %, non-condensing					
Isolation voltage	Type test voltage: 500 V AC (corresponding to 700 V DC)					
Environmental conditions	Industrial					
Protection class	IP20 according to EN 60529, IEC 529					
Certificates and Standards *	CE- marking: Meets EMC directive 2004/108/EC acc. to EN 61000-6-4, EN 61000-6-2 and Low Voltage Directive acc. to EN 61131-2 Electrical Safety: EN 50178, IEC 61131-2, UL 508 Hazardous location: UL 60079-15, cULus Class 1, Zone 2, AEx nA IIC T4, ExnA IIC T4Gc X RoHS compliance: EN 50581:2012 WEEE compliance: DIRECTIVE/2012/19/EU					
TÜV Approval	IEC 61508 SIL3	IEC 61508 SIL3	No	IEC 61508 SIL3	IEC 61508 SIL3	No
Emission	Tested according to EN 61000-6-4 EMC – Generic Emission Standard, Part 2 – Industrial Environment					
Immunity	Tested according to EN 61000-6-2 EMC – Generic Immunity Standard, Part 2 – Industrial Environment					
Height	186 mm (7.3 in.)	186 mm (7.3 in.)	186 mm (7.3 in.)	186 mm (7.3 in.)	186 mm (7.3 in.)	186 mm (7.3 in.)
Width	119 mm (4.7 in.)	59 mm (2.9 in.)	119 mm (4.7 in.)	119 mm (4.7 in.)	59 mm (2.9 in.)	174 mm (6.9 in.)
Depth	135 mm (5.3 in.)	127.5 mm (5.0 in.)	135 mm (5.3 in.)	135 mm (5.3 in.)	127.5 (5.0 in.)	94 mm (3.7 in.)
Weight (including base)	1200 g (2.6 lbs)	700g (1.5 lbs)	1200 g (2.6 lbs)	1200 g (2.6 lbs)	700 g (1.5 lbs)	1600 g (3.5 lbs)

* For detailed information on each module, please visit: www.800xahardwareselector.com

Measurements

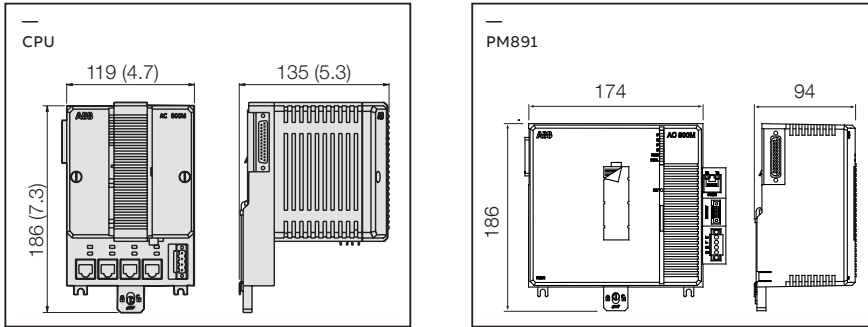

AC 800M Hardware

Hardware Upgrade orders

Hardware Upgrade orders

For Hardware Upgrade orders please send your inquiry to Service Center mail box: offer.selog@se.abb.com

ISA-S71.04 level G3 Compliance

Modules are compliant to ISA-S71.04 level G3, unless explicitly stated differently.

Extended Warranty for AC 800M Hardware

We can offer an extended warranty for one, two, or three years in addition to normal warranty conditions for AC 800M Hardware. See price list Extended Warranty.

03

AC 800M Hardware

System Units

System Units



The Tool Cable TK212A is most useful when working with AC 800M. Please order a cable (Item P215) together with your first order of PM851AK01, PM856AK01, PM857K01, PM857K01, PM858K01, PM858K02, PM860AK01, PM861AK01, PM861AK02, PM862K01, PM862K02, PM863K01, PM863K02, PM864AK01, PM864AK02, PM865K01, PM865K02, PM866AK01, PM866AK02, PM867K01, PM867K02, PM891K01 or PM891K02.

AC 800M Hardware

AC 800M Processor Units

800M Processor Units		Article no.
	PM851AK01 Processor Unit (24MHz and 12 MB) Package including: <ul style="list-style-type: none"> • PM851A, CPU • TP830, Baseplate, width = 115 mm • TB850, CEX-bus terminator • TB807, ModuleBus terminator • Battery for memory backup (4943013-6) • No licence included 	3BSE066485R1
	PM856AK01 Processor Unit (24MHz and 16 MB) Package including: <ul style="list-style-type: none"> • PM856A, CPU • TP830, Baseplate, width = 115 mm • TB850, CEX-bus terminator • TB807, ModuleBus terminator • Battery for memory backup (4943013-6) • No licence included 	3BSE066490R1







AC 800M Hardware

AC 800M Processor Units

800M Processor Units	Article no.	
 <p>PM858K01 Processor Unit (33MHz and 16 MB) Only compatible with 800xA 6.0.2, Compact Control Builder 6.0.0-1 and onwards. Please see Product Update for more information. Package including:</p> <ul style="list-style-type: none"> • PM858, CPU • TP830, Baseplate, width = 115mm • TB850, CEX-bus terminator • TB807, ModuleBus terminator • TB852, RCU-Link terminator • Battery for memory backup (4943013-6) • No license included 	3BSE082895R1	
<p>PM858K02 Redundant Processor Units (33MHz and 16MB) Only compatible with 800xA 6.0.2, Compact Control Builder 6.0.0-1 and onwards. Please see Product Update for more information. Package including:</p> <ul style="list-style-type: none"> • 2 pcs PM858, CPU • 2 pcs TP830, Baseplate, width = 115mm • 2 pcs TB807, ModuleBus terminator • 1 pcs TK850, CEX-bus expansion cable • 1 pcs TK851, RCU-Link cable • 2 pcs Battery for memory backup (4943013-6) • No license included 	3BSE082896R1	
<p>PM860AK01 Processor Unit (48 MHz and 16 MB) Package including:</p> <ul style="list-style-type: none"> • PM860A, CPU • TP830, Baseplate, width = 115 mm • TB850, CEX-bus terminator • TB807, ModuleBus terminator • Battery for memory backup (4943013-6) • No license included 	3BSE066495R1	
<p>PM862K01 Processor Unit (67 MHz and 32 MB) Only compatible with 800xA 6.0.2, Compact Control Builder 6.0.0-1 and onwards. Please see Product Update for more information. Package including:</p> <ul style="list-style-type: none"> • PM862, CPU • TP830, Baseplate, width = 115mm • TB850, CEX-bus terminator • TB807, ModuleBus terminator • TB852, RCU-Link terminator • Battery for memory backup (4943013-6) • No license included 	3BSE076940R1	
<p>PM862K02 Redundant Processor Units (67 MHz and 32 MB) Only compatible with 800xA 6.0.2, Compact Control Builder 6.0.0-1 and onwards. Please see Product Update for more information. Package including:</p> <ul style="list-style-type: none"> • 2 pcs PM862, CPU • 2 pcs TP830, Baseplate, width = 115mm • 2 pcs TB807, ModuleBus terminator • 1 pcs TK850, CEX-bus expansion cable • 1 pcs TB851, RCU-Link cable • 2 pcs Battery for memory backup (4943013-6) • No license included 	3BSE081636R1	



AC 800M Hardware

AC 800M Processor Units

800M Processor Units	Article no.	
 <p>PM866AK01 Processor Unit (133 MHZ and 64 MB) Package including:</p> <ul style="list-style-type: none"> • PM866A, CPU • TP830, Baseplate, width = 115mm • TB850, CEX-bus terminator • TB807, ModuleBus terminator • TB852, RCU-Link terminator • Battery for memory backup (4943013-6) • No license included 	3BSE076939R1	
 <p>PM866AK02 Red. Processor Units (133 MHz and 64 MB) Package including:</p> <ul style="list-style-type: none"> • 2 pcs PM866A, CPU • 2 pcs TP830, Baseplate, width = 115mm • 2 pcs TB807, ModuleBus terminator • 1 pcs TK850, CEX-bus expansion cable • 1 pcs TB851, RCU-Link cable • 2 pcs Battery for memory backup (4943013-6) • No license included 	3BSE081637R1	
 <p>PM891K01 Processor Unit (450 MHZ and 256 MB) Package including:</p> <ul style="list-style-type: none"> • PM891 CPU Module • TB850, CEX-bus terminator • TB853, RCU Control Link Terminator • No license included 	3BSE053241R1	
 <p>PM891K02 Redundant Processor Unit Package including:</p> <ul style="list-style-type: none"> • 2 pcs PM891K01 Processor Unit • 1 pcs TK850V007 CEX-bus Extension Cable • 1 pcs TK855 RCU Data Link Cable • 1 pcs TK856 RCU Control Link Cable • No license included <p>Please note: The BC810K02 is not included in the PM891K02 Redundant Processor Unit kit. In order to make hot replacement of PM891 Processor Unit possible, the BC810K02 is required and has to be ordered separately.</p>	3BSE053242R1	
 <p>SB822 Rechargeable battery unit External DIN-rail mounted rechargeable battery unit including lithium-ion battery, 24V DC connector and connection cable TK821V020. Width=85 mm. Equivalent amount of Lithium metal=0,8g (0,03oz)</p>	3BSE018172R1	
 <p>MB801V512 Compact Flash card Compact Flash memory for AC 800M and Panel 800 Version 5. 512 MB.</p>	3BSE042257R1	

System Units

AC 800M High Integrity Units

AC 800M High Integrity Units	Article no.	
<p>High integrity, certified for SIL3. Requires configuration according to Safety Manual. Local organizations must comply with the Qualifications to secure successful sales of ABB safety systems, to order safety equipment.</p>		
 <p>PM857K01 Processor Unit HI 96MHz and 32MB. Max 128 I/O signals. Only compatible with 800xA 6.1, Control Builder Safe 3 and onwards. Please see Product Update for more information. Package including:</p> <ul style="list-style-type: none"> • PM857, Safety CPU • TP830, Baseplate • TB850, CEX-bus terminator • TB807, ModuleBus terminator • TB852, RCU-Link terminator • Battery for memory backup (4943013-6) • No license included. 	3BSE088385R1	
 <p>PM857K02 Redundant Processor Unit HI 96MHz and 32MB. Max 128 I/O signals. Only compatible with 800xA 6.1, Control Builder Safe 3 and onwards. Please see Product Update for more information. Package including:</p> <ul style="list-style-type: none"> • 2 pcs PM857K01, Safety Processor unit. • TK850, CEX-bus expansion cable. • TK851, RCU-Link cable. • No license included. 	3BSE088386R1	
<p>PM863K01 Processor Unit HI 96MHz and 32MB. Only compatible with 800xA 6.1, Control Builder Safe 3 and onwards. Please see Product Update for more information. Package including:</p> <ul style="list-style-type: none"> • PM863, Safety CPU • TP830, Baseplate • TB850, CEX-bus terminator • TB807, ModuleBus terminator • TB852, RCU-Link terminator • Battery for memory backup (4943013-6) • No license included. 	3BSE088381R1	
<p>PM863K02 Redundant Processor Unit HI 96MHz and 32MB. Only compatible with 800xA 6.1, Control Builder Safe 3 and onwards. Please see Product Update for more information. Package including:</p> <ul style="list-style-type: none"> • 2 pcs PM863K01, Safety Processor unit. • TK850, CEX-bus expansion cable. • TK851, RCU-Link cable. • No license included. 	3BSE088382R1	

AC 800M High Integrity Units	Article no.	
<p>PM867K01 Processor Unit HI (133 MHz and 64 MB) Only compatible for 800xA 6.0.2 and onwards. Please see: Product Update for more information. Package including:</p> <ul style="list-style-type: none"> • PM867, CPU • TP830, Baseplate, width = 115mm • TB850, CEX-bus terminator • TB807, ModuleBus terminator • TB852, RCU-Link terminator • Battery for memory backup (4943013-6) • No license included 	3BSE076355R1	
<p>PM867K02 Red. Processor Units HI (133 MHz and 64MB) Only compatible for 800xA 6.0.2 and onwards. Please see: Product Update for more information. Package including:</p> <ul style="list-style-type: none"> • 2 pcs PM867, CPU • 2 pcs TP830, Baseplate, width = 115mm • 2 pcs TB807, ModuleBus terminator • 1 pcs TK850, CEX-bus expansion cable • 1 pcs TB851, RCU-Link cable • 2 pcs Battery for memory backup (4943013-6) • No license included 	3BSE081638R1	
<p>SM812K01 Safety CPU module Collaborating safety CPU with PM867 processor unit. Use with PM857, PM863 and PM867. Only compatible for 800xA 6.0.2 and onwards. Please see: Product Update for more information. Package including:</p> <ul style="list-style-type: none"> • SM812, Safety Module • TP868, Baseplate, width=60mm • TK852V10, Synchronization link cable 	3BSE072270R1	
<p>SS823 Power Voting Device Required in a High Integrity 800xA system. One per power supply unit, also at redundant configurations. Input d.c. 24 V. Dual 24 V to single 24 V, 20A. DIN rail mounted.</p>	3BSE038226R1	



System Units

Extra Batteries

Extra Batteries



For extra Lithium batteries (4943013-6), please refer to Business Online.

Communication

Control Network



Control Network

No articles, such as cables, hubs, switches etc, for Control Network are included in this price list. Please refer to Product Guide AC 800M, for recommended articles.

Recommended network components are available in 800xA Networks price list.

Communication

Serial Interfaces on TP830

Serial Interfaces on TP830	Article no.	
<p>RS232-C interfaces for protocols COMLI, MODBUS, Siemens 3964R, the free-programmable serial protocol etc. Also for connection of engineering tool.</p>		
 <p>TK212A Tool cable RJ45 8P8C plug Used to connect a PC to CI801, CI840 or CI840A for download of software. Download to CI801 requires a TK527V030 in addition. RJ45 (male) to Dsub-9 (female), length 3 m. RJ45 8P8C plug (with shell). Cable: UL2464 26 AWG x 8C.</p>	3BSC630197R1	
 <p>TC562 Short Distance Modem Length < 10 km. Point-to-point up to 1 km at 19200 bps. G1 compliant. Power 24V d.c. To be used with CI531, CI532Vxx, CI534Vxx, CI853.</p> <p>Note! This part is exempted from the scope of 2011/65/EU (RoHS) as provided in Article 2(4)(c), (e), (f) and (j) therein (ref.: 3BSE088609 – EU DECLARATION OF CONFORMITY - ABB Advant Master Process Control System)</p>	3BSC630049R1	
 <p>TK853V020 Modem Cable, 2m Modem cable for serial interfaces on TP830.</p>	3BSC950201R1	

AC 800M Controller and Communication Interface selection guide

Supported Communication modules	PROFIBUS DP	FOUNDATION FIELDBUS	RS-232 C	MB300
Module	CI854B	CI860	CI853	CI855
Protocol	DP-V1 (PA via Linking Device)	FF HSE (H1 via Linking Device)	MODBUS RTU master, COMLI master/ slave, Siemens 3964R master, User defined protocols	MasterBus 300
Master or slave	Master	Master	Master/slave	Master/slave
Number of channels	2	1	2	2
Max units on CEX bus	12	12	12	12
Transmission speed	9.6 - 12,000 kbit/s	10/100 Mbit/s	75 - 19 200 b/s	10 Mbit/s, 200 Datasets/s
Cable redundancy	Yes	No	No	Yes
Module redundancy	Yes	Yes	No	No
Hot Swap	Yes	Yes	Yes	Yes
Used together with High Integrity Controller	Yes	No	Yes	Yes
Connectors	DB female (9-pin)	RJ-45 female (8-pin)	RJ-45 female (8-pin)	RJ-45 female (8-pin)
24 V current consumption	Typ 190 mA	Typ 100 mA	Typ 100 mA	Typ 150 mA
Protection class	IP20 according to EN60529, IEC 529			
Certification *				
• CE-marked	Yes	Yes	Yes	Yes
• UL 508	Yes	Yes	Yes	Yes
• UL 60079-15 (Class 1 Zone 2)	Yes	Yes	Yes	Yes
• RoHS compliance	EN 50581:2012			
• WEEE compliance	DIRECTIVE/2012/19/EU			
Dimensions	Width 58 x Height 186 x Depth 135 mm (2.3 x 7.3 x 5.3 in.)			
Weight (including base)	700 g (1.5 lbs)	455 g (0.9 lbs)	520 g (1.2 lbs)	700 g (1.5 lbs)

Supported Communication modules	INSUM	Drivebus	S100 I/O	Satt I/O	MODBUS TCP	IEC 61850
Module	CI857	CI858	CI856	CI865	CI867	CI868
Protocol	IEEE 802.3	ABB's DriveBus	ABB's S100 I/O	ABB's Satt I/O	MODBUS TCP	IEC 61850
Master or slave	Master	Master	Master	Master	Master/slave	
Number of channels	1	1 main, 2 aux	1	1	2	1
Max units on CEX bus	6	2	12	4	12	12
Transmission speed	10 Mbit/s	4 Mbit/s	-	-	10/100 Mbit/s (Ch1), 10 Mbit/s (Ch2)	10/100 Mbit/s
Cable redundancy	No	No	No	No	No	No
Module redundancy	No	No	No	No	Yes	No
Hot Swap	Yes	Yes	Yes	Yes	Yes	Yes
Used together with High Integrity Controller	Yes	No	No	No	Yes	Yes
Connectors	RJ-45 female (8-pin)	Fiberoptic	Miniribbon (36-pin)	BNC	RJ-45 female (8-pin)	RJ-45 female (8-pin)
24 V current consumption	Typ 150 mA	Typ 200 mA	Typ 200 mA	Typ 120 mA	Typ 160 mA	Typ 160 mA
Protection class	IP20 according to EN60529, IEC 529					
Certification *						
• CE-marked	Yes	Yes	Yes	Yes	Yes	Yes
• UL 508	Yes	Yes	Yes	Yes	Yes	Yes
• UL 60079-15 (Class 1 Zone 2)	Yes	Yes	Yes	Yes	Yes	Yes
• RoHS compliance	DIRECTIVE/2011/65/EU (EN 50581:2012)					
• WEEE compliance	DIRECTIVE/2012/19/EU					
Dimensions	Width 58 x Height 186 x Depth 135 mm (2.3 x 7.3 x 5.3 in.)					
Weight (including base)	600 g (1.3 lbs)	700 g (1.5 lbs)	600 g (1.3 lbs)	600 g (1.3 lbs)	700 g (1.5 lbs)	700 g (1.5 lbs)

* For detailed information on each module, please visit: www.800xahardwareselector.com

Supported Communication modules	AF100	PROFINET IO	EtherNet/IP DeviceNet
Module	CI869	CI871	CI873
Protocol	Advant Fieldbus 100	PROFINET IO	EtherNet/IP DeviceNet (via LD800DN)
Master or slave	Slave	Master	Master
Number of channels	2	1	1
Max units on CEX bus	4	12	4
Transmission speed	Up to 500 Kbit/s	10/100 Mbit/s	10/100 Mbit/s
Cable redundancy	Yes	No	No
Module redundancy	Yes	Yes	No
Hot Swap	Yes	Yes	Yes
Used together with High Integrity Controller	Yes	Yes	Yes
Connectors	Phoenix (4-pin)	RJ-45 female (8-pin)	RJ-45 female (8-pin)
24 V current consumption	Typ 160 mA	Typ 160 mA	Typ 160 mA
Protection class	IP20 according to EN60529, IEC 529		
UL 508	Yes	Yes	Yes
UL 60079-15 (Class 1 Zone 2)	Yes	Yes	Yes
Dimensions	Width 58 x Height 186 x Depth 135 mm (2.3 x 7.3 x 5.3 in.)		
Weight (including base)	700 g (1.5 lbs)	700 g (1.5 lbs)	700 g (1.5 lbs)

Features	BC810	BC820
Article number	3BSE031155R1	3BSE071500R1
Redundancy	Yes	Yes
High Integrity	Yes	No
Performance	Hot swap supported	Hot swap supported
Power supply	Inputs designated L+ and L- 24 V nominal, variation between 19.2 V DC and 30 V DC.	
Power consumption +24 V typ/max	50 mA typical (70 mA max)	120 mA typical (200 mA max)
Power dissipation typ.	1.2 W typical	2.9 W typical
Temperature, Operating	+5 to +55 °C (+41 to +131 °F)	
Temperature, Storage	-40 to +70 °C (-40 to +158 °F)	
Relative humidity	5 to 95 %, non-condensing	
Protection class	IP20 according to EN60529, IEC 529	
CE- marking	Yes	
Electrical Safety	UL508	UL508
Hazardous location	cULus Class 1, Zone 2, AEx nA IIC T4, ExnA IIC T4Gc X	
Marine certificates	ABS, BV, DNV-GL, LR, RS, CCS	ABS, BV, DNV-GL, LR
RoHS compliance	DIRECTIVE/2011/65/EU (EN 50581:2012)	
WEEE compliance	DIRECTIVE/2012/19/EU	
Height	185 mm (7.3 in.)	185 mm (7.3 in.)
Width	59 mm (2.9 in.)	59 mm (2.9 in.)
Depth	127.5 (5.0 in.)	127.5 (5.0 in.)
Weight	1.5 kg (3.31 lbs) (BC810K02 package)	1.4 kg (3.1 lbs) (BC820K02 package)

Communication

Serial Communication Interface

Serial Communication Interface	Article no.
 <p>RS232-C interfaces for protocols COMLI, MODBUS, Siemens 3964R, the free-programmable serial protocol etc.</p> <p>CI853K01 Dual RS232-C interface For Modbus RTU and COMLI Package including:</p> <ul style="list-style-type: none"> • CI853, Communication Interface • TP853, Baseplate, width = 60 mm 	3BSE018103R1

Communication

MODBUS TCP

MODBUS TCP	Article no.
 <p>CI867K01 Modbus TCP Interface Package including:</p> <ul style="list-style-type: none"> • CI867, Communication Interface • TP867, Baseplate, width = 60mm 	3BSE043660R1

03

Communication

PROFIBUS DP

PROFIBUS DP	Article no.
 <p>The required PROFIBUS network components (Linking Devices, etc) must be ordered from price list PROFIBUS Network Components.</p> <p>CI854BK01 PROFIBUS-DP/V1 Interface Only compatible with 800xA 6.0.3.2, Compact Control Builder 6.0.0-2 and onwards. Please see Product Update for more information. Package including:</p> <ul style="list-style-type: none"> • CI854B, Communication Interface • TP854, Baseplate, width = 60 mm 	3BSE069449R1

Communication

PROFINET IO

PROFINET IO	Article no.
 <p>CI871K01 PROFINET IO Communication Interface Package including:</p> <ul style="list-style-type: none"> • CI871, Communication Interface • TP867, Baseplate, width = 60 mm 	3BSE056767R1

Communication

FOUNDATION Fieldbus

FOUNDATION Fieldbus	Article no.
 <p>The required FOUNDATION Fieldbus network components (Linking devices, etc) must be ordered from price list FOUNDATION Fieldbus Network Components.</p> <p>CI860K01 FOUNDATION Fieldbus HSE interface Package including:</p> <ul style="list-style-type: none"> • CI860, Communication Interface • TP860, Baseplate, width = 60 mm 	3BSE032444R1

Communication

IEC 61850

In order to develop the IEC 61850 configuration in projects, for example creating and editing Substation Configuration Description (SCD) files, one must purchase the IEC 61850 Engineering Tool. The IEC 61850 Engineering Tool is licensed separately from System 800xA licenses, and one license can be used in several projects. Please

refer to Ref. Doc 2PAA113852 for more details on how to purchase and license it. For order of IEC 61850 related products, local organizations must comply with the Demands on the Purchaser to secure successful sales of IEC 61850 with System 800xA. Ref doc, 3BSE058798.

IEC 61850	Article no.
 <p>CI868K01 IEC61850 interface Package including:</p> <ul style="list-style-type: none"> • CI868, Communication Interface • TP867, Baseplate, width = 60mm • A maximum of 120 IEDs (GOOSE) and 40 IEDs (MMS) is allowed per CI868. The combination of both protocols in the same module is allowed. (40IEDs /CI868) 	3BSE048845R1

Communication

Ethernet/IP

Ethernet/IP	Article no.
 <p>CI873K01 Ethernet/IP interface Packaging including:</p> <ul style="list-style-type: none"> • CI873, Communication interface • TP867, Baseplate width = 60mm 	3BSE056899R1

Communication

Advant Fieldbus 100

Advant Fieldbus 100	Article no.	
 <p>CI869K01 AF 100 Communication Interface Package including:</p> <ul style="list-style-type: none"> • CI869, Communication Interface • TP869, Baseplate, width = 60mm <p>Note! This part is exempted from the scope of 2011/65/EU (RoHS) as provided in Article 2(4)(c),(e),(f)and(j)therein(ref.: 3BSE087241 - Technical Overview - ABB Advant Master Process Control System)</p>	3BSE049110R1	

Communication

MasterBus 300

MasterBus 300	Article no.	
 <p>CI855K01 MB 300 interface Package including:</p> <ul style="list-style-type: none"> • CI855, MB300 Interface Module • TP853, Base plate 	3BSE018106R1	

Communication

S100 I/O Bus

S100 I/O Bus	Article no.	
 <p>CI856K01 S100 I/O interface Communication between AC800M and S100 I/O system. Package including:</p> <ul style="list-style-type: none"> • CI856, Communication Interface • TP856, Baseplate, width = 60mm 	3BSE026055R1	

Communication

Satt I/O

Satt I/O		Article no.
	For SATT 19" rack I/O and S200 I/O via ControlNet. For additional Satt 19" rack I/O components, see price list 3BSE014353 (Interface) in price book 3BSE014360 (SattLine/SattCon).	
	CI865K01 SATT I/O interface Package including: <ul style="list-style-type: none"> • CI865, Communication Interface • TP865, Baseplate, width = 60 mm 	3BSE040795R1

Communication

INSUM

INSUM		Article no.
	CI857K01 INSUM Ethernet interface Package including: <ul style="list-style-type: none"> • CI857, Communication Interface • TP853, Baseplate, width = 60 mm 	3BSE018144R1

Communication

DriveBus

DriveBus		Article no.
	CI858K01 DriveBus Interface Package including: <ul style="list-style-type: none"> • CI858, Communication Interface • TP858, Baseplate, width = 60 mm 	3BSE018135R1

Communication

Bus Accessories

Bus Accessories	Article no.	
	TK850V007 CEX-Bus Extension Cable Length = 0.7 m	3BSC950192R1
	TB850 CEX-Bus Terminator With 25-pin DB25P male connector. With screw fixing.	3BSC950193R1
	TB851 CEX-Bus Terminator With 25-pin DB25S female connector. With screw fixing.	3BSC950194R1
	BC810K02 CEX-bus Interconnection Unit Including: <ul style="list-style-type: none"> • BC810, Interconnection Unit, 2 units • TP857, Baseplate, width = 60 mm, 2 units • TK851, Interconnection Cable • TB850, CEX-Bus Terminator, 2 units 	3BSE031155R1
	BC820K02 RCU-Link and CEX-Bus Interconnection Units Allows AC 800M redundant PM858, PM862 or PM866 pair to be up to 200 m apart, cables not included. Including: <ul style="list-style-type: none"> • BC820, RCU-Link and CEX-Bus Interconnection Unit, 2 units • TP850, Baseplate, width = 60mm, 2 units • TK857 RCU-Link Cable for BC820, 2 units • TB850, CEX-Bus Terminator, 2 units 	3BSE071500R1
	TK851V010 Connection Cable Length = 1.0 m. Used as: <ul style="list-style-type: none"> • RCU Link Cable • BC810 Interconnection Cable 	3BSC950262R1
	TB852 RCU Link Terminator Terminator for RCU link.	3BSC950263R1
	TB853 RCU Control Link Terminator Terminator for RCU Control link.	3BSE057022R1
	TK855 RCU Data Link Cable Length = 1.0 m. Used as: RCU Data Link Cable with PM891.	3BSC950356R1
	TK856 RCU Control Link Cable Length = 1.0 m. Used as RCU Control Link Cable with PM891.	3BSE057021R1
	TK857V003 RCU Link Cable Length = 0.3 m. Used with BC820.	3BSC950375R1

AC 800M Power supply and Voters selection guide

Feature	SD822Z	SD831	SD832	SD833	SD834	SS822Z	SS832	SS823	SD853	SD854
Rated output current	5 A	3 A	5 A	10 A	20 A	20 A	10 A (20 A in parallel operation)	20 A	10 A	20 A
Rated output power	120 W	72 W	120 W	240 W	480 W	-	-	-	240 W	480 W
Rated output voltage	24 V d.c.	24 V d.c.	24 V d.c.	24 V d.c.	24 V d.c.	-	-	-	24 V d.c.	24 V d.c.
Rated input power	280 VA 135 W	134/143 VA	240/283 VA	447/514 VA	547/568 VA	500 W	240 W (480 W in parallel operation)	500 W		
Mains/input voltage, nominal	115/230 V a.c. 225-250 V d.c.	100-240 V a.c. 110-300 V d.c.	100-120 V a.c. 200-240 V a.c. Auto-select input	100-120 V a.c. 200-240 V a.c. Auto-select input	100-240 V a.c. 110-150 V d.c.	2x24 V d.c.	2x24 V d.c. (1x24 V d.c. in parallel operation)	1x24 V d.c.	100-240 V a.c. 110-150 V d.c.	100-240 V a.c. 110-150 V d.c.
Mains voltage variation allowed	85 - 110%	90-264 V a.c. 88-375 V d.c.	90-132 V a.c. 180-264 V a.c.	90-132 V a.c. 180-264 V a.c.	85-276 V a.c. 88-375 V d.c.	-	-	-	85-264 V a.c. 88-180 V d.c.	85-264 V a.c. / 88-180 V d.c.
Primary peak inrush current at power on	Typ 15 A	< 28/< 54 A	< 10 A	< 10 A	< 13 A	-	-	-	6 A / 9 A peak	10 A / 4.5 A peak
Applications	SELV and PELV	SELV and PELV	SELV and PELV	SELV and PELV	SELV and PELV	-	-	-	SELV and PELV	SELV and PELV
Load sharing	Two in parallel	-	-	-	Parallel connection	Two in parallel	Two in parallel	Yes	-	Parallel connection
Power Factor (at rated output power)		0.61/0.56	0.56/0.47	0.59/0.51	0.95/0.90	-	-	-	0.99/0.97	0.99/0.95
Heat dissipation	13 W	10/8 W	14/13 W	24/22 W	40/32 W	10 W at 20 A and 2,5 W at 5 A	9 W (18 W)	24 W at 20 A and 6 W at 5 A	16.4 W / 12.1 W, 120/230 V a.c.	29.6/22.1 W, 120/230 V a.c.
Efficiency factor (%)	88	88/89.8	89.4/90.2	91/91.6	92.4/93.9	-	-	-	93.6/95.2	94.2/95.6
Output voltage regulation	+ - 2%	< 50 mV / < 100 mV	< 70 mV / < 100 mV s	< 70 mV / < 100 mV	< 10 mV / < 100 mV	0,5 V lower than input	0,85 V lower than input	1.2 V lower than input	< 50 mV	< 100 mV
Ripple (peak to peak)	< 50 mV	< 50 mV	< 50 mV	< 50 mV	< 100 mV	-	-	-	< 50 mV	50 mV
Secondary voltage holdup time at mains blackout	> 20 ms	29/120 ms	80/78 ms	46/47 ms	32/51 ms	-	-	-	37 ms	32 ms
Maximum output current (min)	10 A	3.3 A	6 A At ambient temp < 45 °C	12 A At ambient temp < 45 °C	30 A < 4 s	35 A (Overload)	25 A (Overload)	35 A (Overload)	12 A At ambient temp < 45 °C	24 A At ambient temp < 45 °C
Maximum ambient temperature	60 °C	60 °C	60 °C	60 °C	60 °C	60 °C	60 °C	55 °C	70 °C	70 °C
Primary: Recommended external fuse ⁽¹⁾	10 A	10-20 A	10-20 A	10-20 A	10-20 A	-	-	-	10-20 A	10-20 A
Secondary: Short circuit	< 10 A	< 8 A	< 14 A	< 18 A	< 40 A	-	-	-	30 A for < 12 ms	60 A for < 12 ms
Secondary: Over-Voltage protection	29 V	< 39 V	< 39 V	< 39 V	< 37 V	-	-	< 30 V	Max 32 V	Max 32 V
Class of protection	I PE (Protective Earth) connection required					-	-	-	I PE (Protective Earth) connection required	
Protection rating	IP20 according to IEC60529									

⁽¹⁾ Microcircuit Breaker (MCB), Characteristic B

AC 800M Power supply and Voters selection guide

Feature	SD822Z	SD831	SD832	SD833	SD834	SS822Z	SS832	SS823	SD853	SD854
Width	65 mm (2.56 in.)	32 mm (1.26 in.)	32 mm (1.26 in.)	60 mm (2.36 in.)	82 mm (3.23 in.)	50 mm (1.97 in.)	32 mm (1.26 in.)	116 mm (4.6 in.)	39 mm (1.53 in.)	48 mm (1.88 in.)
Depth	110 mm (4.3 in.)	102 mm (4.02 in.)	117 mm (4.61 in.)	117 mm (4.61 in.)	127 mm (5.0 in.)	110 mm (4.3 in.)	117 mm (4.61 in.)	145 mm (5.8 in.) including connector	117 mm (4.60 in.)	127 mm (5.00 in.)
Height	125 mm (4.9 in.)	124 mm (4.88 in.)	124 mm (4.88 in.)	124 mm (4.88 in.)	124 mm (4.88 in.)	125 mm (4.9 in.)	125 mm (4.9 in.)	132 mm (5.3 in.)	124 mm (4.88 in.)	124 mm (4.88 in.)
Mounting spacing Width mm	15 mm (0.59 in.)	15 mm (0.59 in.)	15 mm (0.59 in.)	15 mm (0.59 in.)	15 mm (0.59 in.)	15 mm (0.59 in.)	15 mm (0.59 in.)	15 mm (0.6 in.)	15 mm (0.59 in.)	15 mm (0.59 in.)
Mounting spacing Height mm	25 mm (1 in.)	40 mm (1.57 in.)	40 mm (1.57 in.)	40 mm (1.57 in.)	40 mm (1.57 in.)	25 mm (1 in.)	25 mm (1 in.)	25 mm (1.2 in.)	40 mm (1.57 in.)	40 mm (1.57 in.)
Weight (lbs.)	620 g (1.4 lbs)	430 g (0.9 lbs.)	500 g (1.1 lbs.)	700 g (1.5 lbs.)	1200 g (2.6 lbs.)	630 g (1.4 lbs)	350 g (0.77 lbs.)	870 g (1.9 lbs.)	600 g (1.32 lbs)	830 g (1.83 lbs)
Corrosive atmosphere ISA-571.04	G3	G2	G2	G2	G2	G3	G2	G3	G3	G3
CE mark	Yes	Yes	Yes	Yes	Yes	Yes	Yes	Yes	Yes	Yes
El. safety, Haz loc, C1 Zone 2	No	No	No	No	No	No	No	No	Yes	Yes
El. safety, Haz loc, C1 Div 2	No	No	No	No	Yes	No	No	No	Yes	No
Electrical safety	IEC 61131-2, UL 508, EN 50178 (Note! UL 508 not valid for SS823)								IEC 60950-1	
Pollution degree	Degree 2, IEC 60664-1									
Mechanical operating conditions	EN 61131-2									
EMC	EN 61000-6-4 and EN 61000-6-2									
Over voltage Categories ⁽²⁾	Over-voltage Category III (IEC/EN 60664-1)									
RoHS compliance	DIRECTIVE/2011/65/EU (EN 50581:2012)									
WEEE compliance	DIRECTIVE/2012/19/EU									

⁽²⁾ For detailed information on each module, please visit: www.800xahardwareselector.com

AC 800M Processor Units

AC 800M Power supply and Voters

Power Supply		Article no.
	SD822Z Power Supply, 5A Input 115/230V a.c. switch selectable, output 24V d.c., 5A. If redundant power application is required connect to SS822Z voting unit. DIN rail mounted.	3BSC610054R1
	SD831 Power Supply, 3A Input a.c. 100-240 V or d.c. 110-300 V. Output d.c. 24 V 3A. If redundant power application is required connect to SS8XX voting unit. DIN rail mounted. G2 compliant.	3BSC610064R1
	SD832 Power Supply, 5A Input a.c. 100-120/200-240 V. Output d.c. 24 V 5A, auto-select input. If redundant power application is required connect to SD8XX voting unit. DIN rail mounted. G2 compliant.	3BSC610065R1
	SD833 Power Supply, 10A Input a.c. 100-120/200-240 V, auto-select input. Output d.c. 24 V 10A. If redundant power application is required connect to SD8XX voting unit. DIN rail mounted. G2 compliant.	3BSC610066R1
	SD834 Power Supply, 20A Input a.c. 100-240 V or d.c. 110-150 V. Output d.c. 24 V 20A. If redundant power application is required connect to SS8XX voting unit. DIN rail mounted. G2 compliant.	3BSC610067R1
	SD853 Power Supply 10A 10A Power Supply Module. Input AC 100-240V. Input DC 110-150V. Output DC 24-28V. Mounting on horizontal DIN rail. Width 39 mm.	3BSE088188R1
	SD854 Power Supply 20A 20A Power Supply Module. Input AC 100-240V. Input DC 110-150V. Output DC 24-28V. Mounting on horizontal DIN rail. Width 48 mm.	3BSE088189R1
	SS822Z Power Voting Unit With dual 24V d.c 20A inputs, single 24V d.c. 20A output. Each power input supervised. Used if redundant power supply is required. For use with power supply SD822Z. DIN rail mounted.	3BSC610055R1
	SS832 Power Voting Unit Input d.c. 24 V. Dual 24 V to single 24 V, 2x10A. DIN rail mounted. G2 compliant.	3BSC610068R1
	Mains Breaker Kit for DIN Rail 115/230V a.c. with input terminals, breaker and 3 fused (6.3A). Double output terminals. Width = 102,5 mm.	3BSE022262R1

AC 800M Processor Units

AC 800M Mounting Rails

AC 800M Mounting Rails		Article no.
	Al-profile with DIN Rail, C. Duct, 28,3" Mounting 719 mm (28,3") DIN rail length 683 mm (26,9")	3BSE022257R1
	Al-profile with DIN Rail, C. Duct, 24" Mounting 592 mm (24") DIN rail length 556 mm (21,9")	3BSE022256R1
	Al-profile with DIN Rail, C. Duct, 19" Mounting 465 mm (19") DIN rail length 429 mm (16,9")	3BSE022255R1

Select I/O

ABB Ability™ System 800xA offers flexible and modular I/O solutions through fieldbus technologies, wireless I/O and hardwired I/O systems such as S800 and S900. The system is now enhanced with Select I/O that allows individual conditioning of each signal coming from the field. Select I/O is Ethernet connected and consists of single channel granular Signal Conditioning Modules (SCM).



Select I/O selection guide

	Signal Type	Signal Range	HART	SOE	Galvanic Isolation	Loop Supervision	Current Limitation	CE	ATEX Zone 2	cULus Class 1 Division 2	High Integrity SIL 3
AIS810	Analog In	4...20mA	●		ch-2-ch	●	●	●	●	Pending	
AIS880	Analog In	4...20mA	●		ch-2-ch	●	●	●	●	Pending	●
DIS810	Digital In	24V		●	ch-2-ch	●	●	●	●	Pending	
DIS880	Digital In	24V		●	ch-2-ch	●	●	●	●	Pending	●
AOS810	Analog Out	4...20mA	●		ch-2-ch	●	●	●	●	Pending	
AOS880	Analog Out	4...20mA	●		ch-2-ch	●	●	●	●	Pending	●
DOS810	Digital Out	24V, 0.6A			Group	●	●	●	●	Pending	
DOS880	Digital Out	24V, 0.6A			Group	●	●	●	●	Pending	●
DOS885	Digital Out	24V, 3A			Group	●	●	●	●	Pending	●
GIS810	GIO	NA			NA	NA	NA	●	●	Pending	
GIS880	GIO	NA			NA	NA	NA	●	●	Pending	●

Measurements

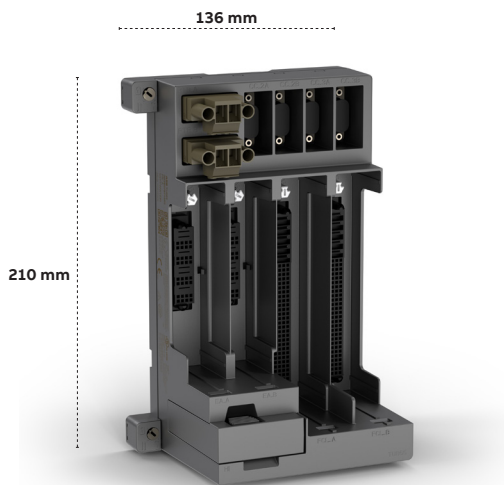

TU865 Ethernet FCI MTU

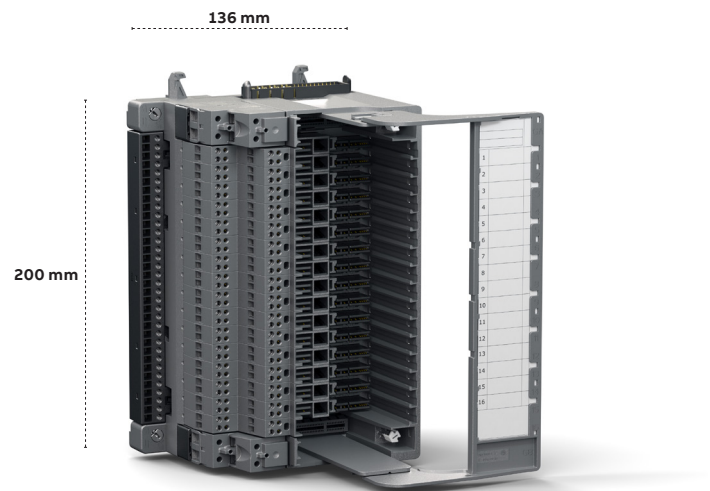

TUS810 Select I/O MTU

Select I/O

Extended warranty for Select I/O Hardware

We can offer an extended warranty for one, two, or three years in addition to normal warranty conditions for Select I/O Hardware.





See price list Extended Warranty Time.

ISA-S71.04 level G3 compliance

Modules are compliant to ISA-S71.04 level G3, unless explicitly stated differently.

Communication

Field Communication Interface

Field Communication Interface	Article no.	
 <p>CI845 Ethernet FCI module Ethernet Fieldbus Communication Interface Module for connection of S800 I/O or Select I/O to Ethernet. For redundant configuration two Fieldbus Communication Interfaces CI845, two Ethernet Adapters TC810 and one TU860 or one TU865 are needed. For Select I/O High Integrity SIL3 one HI880 is needed.</p>	3BSE075853R1	
 <p>TU865 MTU for Ethernet FCI and Select IO Ethernet Fieldbus Communication Interface Module Termination Unit for connection of single or redundant Select I/O. Supports single or redundant Ethernet Fieldbus Communication Interface Module, single or redundant Ethernet Adapter and High Integrity Module. Mounting on vertical DIN-rail.</p>	3BSE078712R1	
 <p>TC810 Ethernet Adapter for Ethernet FCI Ethernet Adapter for copper media with built in 2-port switch. Hosts two RJ45 ports. Use as single or redundant.</p>	3BSE076220R1	
 <p>HI880 HI Module for Ethernet FCI High Integrity Module enables High Integrity SIL3 communication with the Select I/O.</p>	3BSE078701R1	

Select I/O Modules

I/O Modules

I/O Modules	Article no.	
 <p>GIS810 Generic I/O Module Generic I/O Module. Use as single or redundant.</p>	3BSE078740R1	
<p>AIS810 Analog Input 4 to 20mA Analog Input Signal Conditioning Module for 2/4-wire devices. 16 bit. HART communication.</p>	3BSE078762R1	
<p>AOS810 Analog Output 4 to 20mA Analog Output Signal Conditioning Module for 2-wire devices. 16 bit. HART communication.</p>	3BSE078764R1	
<p>DIS810 Digital Input 24V Digital Input 24V Signal Conditioning Module for 2/3/4-wire devices. Sequence of Events (SOE) enabled.</p>	3BSE078766R1	
<p>DOS810 Digital Output 24V 0.6A Digital Output 24V 0.6A Signal Conditioning Module.</p>	3BSE078768R1	







Select I/O Modules

High Integrity I/O Modules

High Integrity I/O Modules	Article no.	
 <p>The modules can only be connected to a AC800M controller PM857, PM863 or PM867 via CI845.</p>		
<p>GIS880 Generic I/O Module High Integrity Generic I/O Module High Integrity. Certified for SIL3. Use as single or redundant.</p>	3BSE075855R1	
<p>AIS880 Analog Input 4 to 20mA HI Analog Input Signal Conditioning Module High Integrity for 2/4-wire devices. 16 bit. HART communication. Certified for SIL3.</p>	3BSE074053R1	
<p>AOS880 Analog Output 4 to 20 mA HI Analog Output Signal Conditioning Module High Integrity for 2-wire devices. 16 bit. HART communication. Certified for SIL3.</p>	3BSE074055R1	
<p>DIS880 Digital Input 24V HI Digital Input 24V Signal Conditioning Module High Integrity for 2/3/4-wire devices. Sequence of Events (SOE) enabled. Certified for SIL3.</p>	3BSE074057R1	
<p>DOS880 Digital Output 24V 0.6A HI Digital Output 24V 0.6A Signal Conditioning Module High Integrity. Certified for SIL3.</p>	3BSE074059R1	
<p>DOS885 Digital Output 24V 3A HI Digital Output 24V 3A Signal Conditioning Module High Integrity. Certified for SIL3.</p>	3BSE074061R1	





Select I/O Modules

Module Termination Units

Module Termination Units	Article no.	
 <p>TUS810K01 MTU for Select I/O Select I/O Module Termination Unit TUS810K01 includes 1ps TUS810, 16ps FTB810 Field Terminal Blocks, 2ps PTB810 Power Injection Terminal Blocks and 1ps TUC810 Terminal Cover. Mounting on vertical DIN-rail.</p>	3BSE083204R1	
 <p>GTB810 Grounding Terminal Bar Grounding Terminal Bar with 34 screw terminals for the Select I/O Module Termination Unit. Used to ground shields and spare cores.</p>	3BSE078722R1	
 <p>FTB810K01 Field Terminal Block 4-wire Field Terminal Block with screws for the Select I/O Module Termination Unit. 10 pieces per package.</p>	3BSE088180R1	
 <p>PTB810K01 Power Injection Terminal Block Power Injection Terminal Block with screws for the Select I/O Module Termination Unit. 10 pieces per package.</p>	3BSE088182R1	
 <p>TUC810K01 Terminal Cover Terminal Cover which holds user labels for the Select I/O Module Termination Unit. 10 pieces per package.</p>	3BSE088181R1	
 <p>TS810K01 Screw Lugs Screw lugs for TU860/TU865 and TUS810. 100 pieces per package.</p>	3BSE090351R1	





Select I/O Modules

ModuleBus Communication Parts

ModuleBus Communication Parts	Article no.
 <p>TB868 Modulebus Terminator One Modulebus Terminator is needed per cluster.</p>	3BSE088162R1
 <p>TB861V009 Compact Modulebus Extension Extends the Modulebus from one DIN-rail to another. Length 0.9m.</p>	3BSE088163R1
 <p>TB861V011 Compact Modulebus Extension Extends the Modulebus from one DIN-rail to another. Length 1.1m.</p>	3BSE090352R1
 <p>TB861V015 Compact Modulebus Extension Extends the Modulebus from one DIN-rail to another. Length 1.5m.</p>	3BSE088164R1



Select I/O Modules

Empty Slot Protectors

Empty Slot Protectors	Article no.
 <p>TL810K01 Empty slot protector for FCI Empty slot protector for a Fieldbus Communication Interface slot on the Ethernet FCI Module Termination Unit. 10 pieces per package.</p>	3BSE088170R1
 <p>TL811K01 Empty slot protector for EA Empty slot protector for a Ethernet Adapter slot on the Ethernet FCI Module Termination Unit. 10 pieces per package.</p>	3BSE088171R1
 <p>TL812K01 Empty slot protector for GIO Empty slot protector for a Generic I/O Module slot on the Select I/O Module Termination Unit. 10 pieces per package.</p>	3BSE088172R1
 <p>TL813K01 Empty slot protector for SCM Empty slot protector for a Signal Conditioning Module slot on the Select I/O Module Termination Unit. 10 pieces per package.</p>	3BSE088173R1
 <p>TL814K01 Empty slot protector HI Module Empty slot protector for a High Integrity Module slot on the Ethernet FCI Module Termination Unit. 10 pieces per package.</p>	3BSE088174R1

Select I/O Modules

Power Supply

Power Supply	Article no.
 <p>SD853 Power Supply 10A 10A Power Supply Module. Input AC 100-240V. Input DC 110-150V. Output DC 24-28V. Mounting on horizontal DIN rail. Width 39mm.</p>	3BSE088188R1
 <p>SD854 Power Supply 20A 20A Power Supply Module. Input AC 100-240V. Input DC 110-150V. Output DC 24-28V. Mounting on horizontal DIN rail. Width 48mm.</p>	3BSE088189R1

S800 I/O Modules

S800 I/O is a comprehensive and modular process I/O system that communicates with parent controllers either direct connected using the Modulebus or over industry-standard field buses. Thanks to its broad connectivity it fits a wide range of process controllers from ABB and others.

By permitting installation in the field, close to sensors and actuators, S800 I/O reduces the installation cost by reducing the cost of cabling. And thanks to features such as hot swap of modules, on-line reconfiguration and redundancy options, it contributes to keeping production – and thereby profits up.

S800 I/O features include:

- Comprehensive coverage
- Flexible configuration and installation
- Ease of set up
- Reliability and accuracy

- HART pass-through
- Redundancy also on I/O module level
- High Integrity I/O modules certified to SIL3
- High accuracy time tagging
- Defined outputs at communication errors
- I/O modules with Intrinsic Safety interfaces

With its cost-effective design and just 59 mm depth installation, S800L I/O modules are the perfect choice for PLC applications. Robust mechanics, one-piece handling, easy mounting and smart connections save your time in all phases of installation. The comprehensive S800 I/O system consists of more than 40 different module types to respond to every need. Classification of corrosive protection, electrical safety, hazardous location and marine certification brings the possibility to install S800 I/O in a wide variety of applications. S800 I/O is installed with more than 40 million channels worldwide.

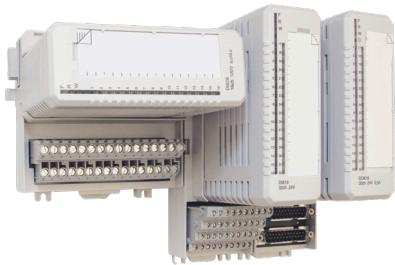

S800 I/O



S800 I/O

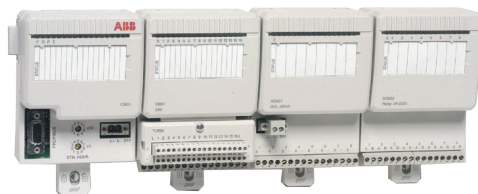

S800L I/O



S800 HI I/O

S800 I/O Modules

Digital input modules

DI810	16 channels, 2 groups of 8 channels, 24 V d.c., current sink.
DI811	16 channels, 2 groups of 8 channels, 48 V d.c., current sink.
DI814	16 channels, 2 groups of 8 channels, 24 V d.c., current source.
DI818	32 channels, 2 groups of 16 channels, 24 V d.c., current sink.
DI820	8 channels, separate returns, 110 V d.c., 120 V a.c.
DI821	8 channels, separate returns, 220 V d.c., 230 V a.c.
DI825	With time tagging, 8 channels, separate returns, 125 V d.c.
DI828	16 channels, separate returns, 110 V d.c., 120 V a.c. / d.c.
DI830	With time tagging. 16 channels, 2 groups of 8 channels, 24 V d.c., current sink. Resolution: < 0.5 ms.
DI831	With time tagging. 16 channels, 2 groups of 8 channels, 48 V d.c., current sink. Resolution: < 0.5 ms.
DI885	With time tagging & wire-fault detection. 8 channels, common return, 24-48 V d.c., current sink. Resolution: 1 ms.

Pulse input module

DP820	2 channels, separate returns, 0.25 Hz - 1.5 MHz, signal voltage: 5 / 12 V d.c.
DP840	8 channels, extended diagnostics, wire-fault detection, current limited sensor supply, 0.5-20 kHz, 12/24 V d.c or NAMUR, common return.

Digital output modules

DO810	16 channels, 2 groups of 8 channels, 24 V d.c., max 0.5 A d.c., transistor, current source, short-circuit-proof.
DO814	16 channels, 2 groups of 8 channels, 24 V d.c., max 0.5 A, transistor, current sink, short-circuit-proof.
DO815	8 channels, 2 groups of 4 channels, 24 V d.c., max 2 A, transistor, current source, short-circuit-proof, wire-fault detection.
DO818	32 channels, 2 groups of 16 channels, 24 V, max 0.5 A d.c., transistor, current source, short-circuit-proof
DO820	8 channels, separate returns, 5-250 V, max 3 A a.c./d.c., relay (N.O.).
DO821	8 channels, separate returns, 5-250 V, max 3 A a.c./d.c., relay (N.C.).
DO828	16 channels, separate returns, 5-250V a.c. / 5-125V d.c. max 2A a.c./d.c., relay (N.O.).

Analog input modules

AI810	8 channels, single-ended, 0(4)-20 mA, 0(2)-10 V, 12 bits.
AI815	8 channels with HART. 0(4)..20 mA, 0(1)..5 V, 12 bit, single ended, current limited transmitter supply.
AI820	Differential inputs, 4 channels, 0(1)-5 V, $\pm 0(2)$ -10 V, $\pm 0(4)$ -20 mA, 14 bits + sign.
AI825	Individually galvanically isolated channels, 4 channels, $\pm 0(2)$ -10 V, $\pm 0(4)$ -20 mA, 14 bits + sign.
AI830A	RTD inputs, 8 channels, Pt100, Ni100, Ni120, Cu10, resistor 0-400 ohms, 14 bits, 3-wire.
AI835A	TC inputs, 8 channels, (7+ ref. junction), separate returns. TC types B, C, D, E, J, K, L, N, R, S, T, U, -30...75 mV, 15 bits.

Analog output modules

AO810V2	8 channels, common return, 0(4)-20 mA, 14 bits, load: 850 ohms (short-circuit-proof).
AO815	8 channels with HART. 4..20 mA, 12 bit, load: 750 ohms, common return, short-circuit-proof.
AO820	4 channels, individually galvanically isolated, separate returns, measuring range: $\pm 0(2)$ -10 V, $\pm 0(4)$ -20 mA, resolution: 12 bits + sign, load: 500 ohms (current) / 5 kohms (voltage), short-circuit-proof.

Intrinsic-safety modules

DI890	8 channels, separate returns, proximity sensors (NAMUR) or voltage-free contact., current sink, wire-fault detection.
DO890	4 channels, separate returns, load 150-5000 ohms, 11 V @ 40 mA, current source, wire-fault detection, short circuit-proof.
AI890	8 channels, single-ended, 0(4)-20 mA, 12 bits, transmitter power supply.
AI893	8 channels, TC: 7 + ref. junction, sep. returns. TC types B, C, E, J, K, L, N, R, S, T, U, -10...80 mV. RTD: Pt50-1000, Ni100-500, Cu10-100, resistor 0-4000 W, 3-wire. 15 bits + sign.
AI895	8 channels, single-ended, 4-20 mA, 12 bits, transmitter power supply, HART pass-through.
AO890	8 channels, common return, 0(4)-20 mA, 12 bits, load: 725 ohms short-circuit-proof.
AO895	8 channels, common return, 4-20 mA, 12 bits, load: 725 ohms short-circuit-proof, HART pass-through.

Redundant modules

DI840	16 channels, common return, 24 V d.c., current sink, extended diagnostics, time-tagging, current limited sensor supply.
DP840	8 channels, common return, 0.5-20 kHz, 12/24 V d.c or NAMUR, extended diagnostics, wire-fault detection.
DO840	16 channels, common return, 24 V d.c., max. 0.5 A, transistor, current source, short-circuit-proof, extended diagnostics.
AI843	TC input, 8 channels + ref. junction. TC types: B, C, E, J, K, L, N, R, S, T, U, -30...75 mV, 16 bits, extended diagnostics.
AI845	8 channels, 12 bits, 0(4)-20 mA 0(1)-5 V, extended diagnostics, HART pass-through, current limited transmitter supply, single ended.
AO845A	8 channels, 12 bits, common return, 4-20 mA, extended diagnostics, HART pass-through, 750 ohms.

S800L I/O Modules

S800L modules	
DI801	16 channels, 1 group, 24 V d.c., current sink.
DI802	8 channels, 110 V d.c., 150 V a.c.
DI803	8 channels, 220 V d.c., 230 V a.c.
DO801	16 channels, common return, 24 V, max 0.5 A d.c., transistor, current source, short-circuit-proof.
DO802	8 channels, 5-250 V, max 2 A a.c./d.c., relay (N.O.).
AI801	8 channels, single-ended, 0(4)-20 mA, 12 bits.
AO801	8 channels, common return, 0(4)-20 mA, 12 bits, load: less than 750 ohms.
Accessories	
TU805K01	For DI801 & DO801. With field power distribution screw terminals. For two or three wire connection.

Environmental Data for S800 I/O *

Climatic Operating Conditions	+5 to +55 °C (Storage -40 to +70 °C, RH = 5 to 95 % no condensation, IEC/EN 61131-2)
Protection class	IP20 according to EN 60529, IEC 529
Corrosive protection	G3 compliant according to ISA-71.04
Electromagnetic Compatibility	Meets EMC directive 2004/108/EC according to EN 61000-6-2 and EN 61000-6-4
Electromagnetic Emission	Tested according to EN 61000-6-4 EMC – Generic Emission Standard, Part 2 – Industrial Environment
Electromagnetic Immunity	Tested according to EN 61000-6-2 EMC – Generic Immunity Standard, Part 2 – Industrial Environment
Electrical Safety	UL508, IEC/EN 61131-2
Hazardous Classified Locations	C1 Div 2 cULus, C1 Zone 2 cULus, ATEX Zone 2
Safety Integrity (IEC 61508)	PM865/SM811, PM867/SM812, AI880A, DI880, DO880: IEC 61508 up to SIL3
CE mark	Yes
RoHS compliance	EN 50581:2012
WEEE compliance	DIRECTIVE/2012/19/EU

* For detailed information on each module, please visit: www.800xAhardwareselector.com

Measurements

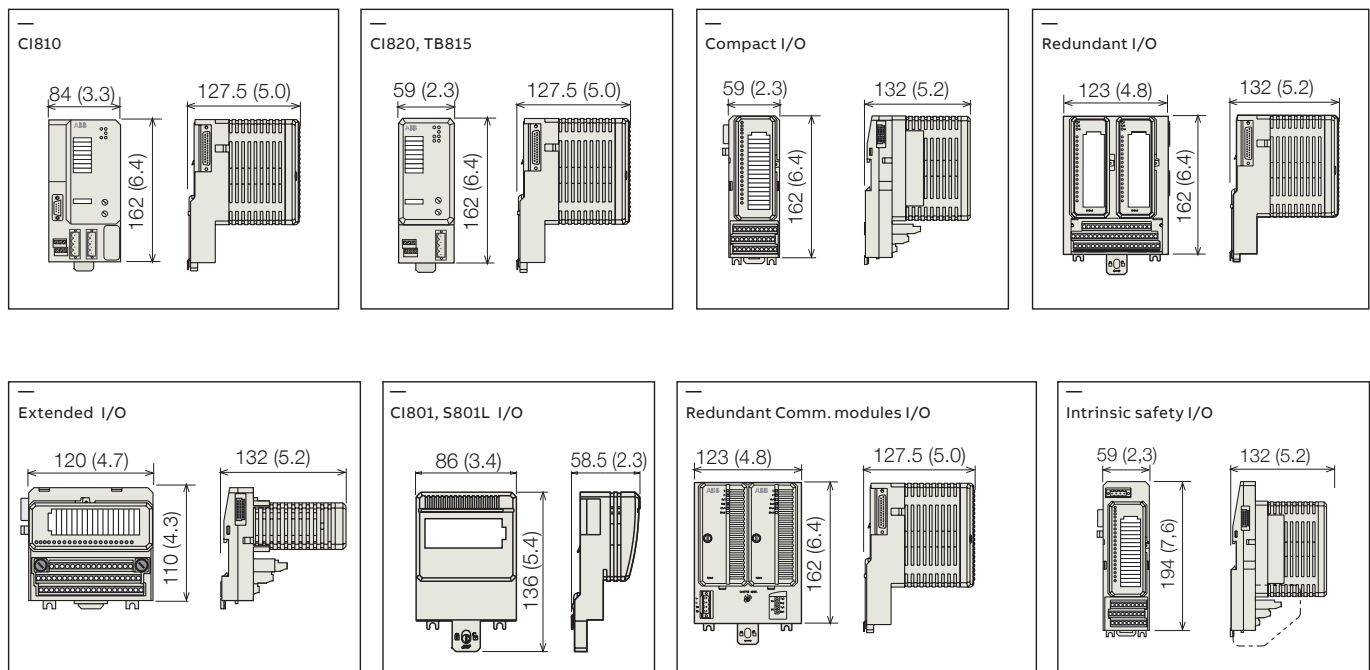

Dimensions in mm (in.)

S800 I/O modules selection guide

	NAMUR inputs	Binary 24 V	Binary 48 V	Binary 110 V	Binary 230 V	Binary Relay	Analog Unipolar	Analog Bipolar	Temperature RTD	Temperature T/C	SOE	HART	Intrinsic safety	Redundant	High integrity	
I/O Features S800																
Digital input modules																
DI810		•														
DI811		•	•													
DI814		•														
DI818		•														
DI820				•												
DI821					•											
DI825				•							•					
DI828				•							•					
DI830		•									•					
DI831			•								•					
DI840		•									•			•		
DI880		•									•			•	•	
DI885		•	•								•			•		
DI890	•												•			
Digital output modules																
DO810		•														
DO814		•														
DO815		•														
DO818		•														
DO820						•										
DO821						•										
DO828						•										
DO840		•												•		
DO880		•												•	•	
DO890													•			
Pulse input modules																
DP820		•														
DP840	•	•												•		
Analog input modules																
AI810							•									
AI815							•					•				
AI820								•								
AI825								•								
AI830A									•							
AI835A										•						
AI843										•				•		
AI845							•					•		•		
AI880A							•					•		•	•	
AI890							•						•	•		
AI893									•	•			•	•		
AI895							•					•	•			
Analog output modules																
AO810V2							•									
AO815							•					•				
AO820								•								
AO845A							•					•		•		
AO890							•						•			
AO895							•					•	•			
S800L modules																
DI801		•														
DI802				•												
DI803					•											
DO801		•														
DO802						•										
AI801							•									
AO801							•									

S800 I/O Communication interfaces

Feature	CI801	CI840A	CI845	TC810
Article number	3BSE022366R1	3BSE041882R1	3BSE075853R1	3BSE076220R1
Function	PROFIBUS-DPV1 fieldbus communication interface. Supervisory functions of I/O ModuleBus. Isolated power supply to I/O modules. OSP handling and configuration. Input power fused. Hot Configuration In Run. HART pass-through.	PROFIBUS-DPV1 fieldbus communication interface. Supervisory functions of I/O ModuleBus. Isolated power supply to I/O modules. OSP handling and configuration. Input power fused. Power supply supervision. Hot Configuration In Run. HART pass-through.	Ethernet fieldbus communication interface. Supervisory functions of I/O ModuleBus. Isolated power supply to I/O modules. OSP handling and configuration. Single/redundant 24V power supply with built-in voting and power supply supervision. Hot Configuration In Run. HART pass-through and Sequence of Events.	Ethernet Adapter for copper media with built in 2-port switch. Hosts two RJ45 ports. Use as single or redundant, together with CI845 and TU860.
Redundant	No	Yes	Yes	Yes
Power Input	24 V d.c. (19.2 - 30)	24 V d.c. (19.2 - 30)	24 V d.c. (19.2 - 30)	24 V d.c. (19.2 - 30)
Power Input Fuse	2 AF	2 AF	2 AF	2 AF
Power Consumption at 24 V d.c.	140 mA	190 mA	150 mA	60 mA
Power Supply Monitoring Inputs	N/A	Max. input voltage: 30 V Min. input voltage for high level: 15 V Max. input voltage for low level: 8 V	Max. input voltage: 30 V Min. input voltage for high level: 15 V Max. input voltage for low level: 8 V	Max. input voltage: 30 V Min. input voltage for high level: 15 V Max. input voltage for low level: 8 V
Power Dissipation	5.4 W	7.7 W	5 W	0.8 W
Maximum Ambient Temperature	55°C (131°F) Horizontal mounted 40°C (104°F) Vertical mounted	55°C (131°F) Horizontal mounted 40°C (104°F) Vertical mounted	-40°C (-40°F) to +70°C (158°F)	-40°C (-40°F) to +70°C (158°F)
Electrical ModuleBus	Maximum of 12 I/O modules	Maximum of 12 single I/O modules or 6 pairs of redundant I/O modules	Maximum of 12 single I/O modules or 12 pairs of redundant I/O modules	N/A
Optical ModuleBus	Maximum of 7 I/O clusters via TB842	Maximum of 7 I/O clusters via TB842	N/A	N/A
Max optical cable length	N/A	N/A	N/A	N/A
Power Output - ModuleBus	24 V max. = 1.5 A fused (1). 5 V max. = 1.5 A current lim.	24 V max. = 1.5 A current lim. 5 V max. = 1.5 A current lim.	24 V max. = 2x 1.5 A current lim. 5 V max. = 2x 1.5 A current lim.	N/A
Module termination units	N/A	TU846 or TU847	TU860 or TU865	TU860 or TU865
MTU Keying code	N/A	AA	A	A
Dielectric test voltage	500 V a.c.	500 V a.c.	500 V a.c.	500 V a.c.
Rated insulation voltage	50 V	50 V	50 V	50 V
Width	85.8 mm (3.38 in.)	54 mm (2.13 in.)	33 mm (1.18 in.)	110 mm (4.33 in.)
Depth	58.5 mm (2.30 in.)	96 mm (3.78 in.)	121.7 mm (4.79 in.)	76.3 mm (3.0 in.)
Height	136 mm (5.35 in.)	119 mm (4.69 in.)	135 mm (5.31 in.)	24.5 mm (0.96 in.)
Weight	300 g (0.66 lbs.)	200 g (0.44 lbs.)	225 g (0.49 lbs.)	105 g (0.23 lbs.)
Climatic operating conditions	0 to +55 °C (Storage -25 to +70 °C), RH=5 to 95 % no condensation, IEC/EN 61131-2 ⁽²⁾		-40 to +70 °C (Storage -40 to +85 °C), RH=5 to 95 % no condensation, IEC/EN 61131-2	
Certificates and standards ⁽³⁾	CE mark: Yes Electrical safety: IEC 61131-2, UL 508 Hazardous Location: C1 Div 2 cULus, C1 Zone 2 cULus, ATEX Zone 2 ⁽⁴⁾ Marine certification: ABS, BV, DNV-GL, LR, RS, CCS ⁽⁴⁾ Corrosive atmosphere ISA-S71.04: G3 Pollution degree: Degree 2, IEC 60664-1 Mechanical operating conditions: IEC/EN 61131-2 EMC: EN 61000-6-4 and EN 61000-6-2 Overvoltage categories: IEC/EN 60664-1, EN 50178 Equipment class: Class I according to IEC 61140; (earth protected) RoHS compliance: EN 50581:2012 WEEE compliance: DIRECTIVE/2012/19/EU			

(1) Fuse type: Subminiature fuse 3.15 A

- LT-5 Fast-Acting 622 series according to Littelfuse
- TR5-F Fuse-link No. 370 according to Wickmann
- MSF 250 according to Schurter

(2) 0 to +40 °C compact MTUs on vertical DIN-rail. Approvals are issued for +5 to +55 °C.

(3) For detailed information on each module, please visit: www.800xahardwareselector.com

(4) Pending for CI845/TC810

Feature	TB820V2	TB825	TB826	TB840A	TB842
Article number	3BSE013208R1	3BSE036634R1	3BSE061637R1	3BSE037760R1	3BSE022464R1
Function	2 fiber optic ports to optical ModuleBus. ModuleBus (electrical) to the I/O Modules. Supervisory functions of I/O ModuleBus and power supply. Isolated power supply to I/O modules. Input power fused.	ModuleBus optical media converter from plastic or HCS fibre with versatile link connector to glass fibre with ST connector. Allows distribution of the optical ModuleBus up to 1000 m per cluster in star configurations.	ModuleBus optical media converter from plastic or HCS fibre with versatile link connector to glass fibre with SC connector. Allows distribution of the optical ModuleBus up to 5000 m per cluster in star configurations.	2 fiber optic ports to optical ModuleBus. ModuleBus (electrical) to the I/O Modules. Supervisory functions of I/O ModuleBus and power supply. Isolated power supply to I/O modules. Input power fused.	Communication interface between the CI801 or CI840/CI840A FCI and the TB820/TB820V2/TB840/TB840A ModuleBus Modem of an I/O cluster or ABB drives units via the Optical ModuleBus. TB842 connects to CI801 via TB806 and to CI840/CI840A via TU847 and TB806 for single I/O or via TU846 and TB846 for redundant I/O.
Redundant	No	No	No	Yes	Yes
Power Input	24 V d.c. (19.2 - 30)	24 V d.c. (19.2 - 30)	24 V d.c. (19.2 - 30)	24 V d.c. (19.2 - 30)	N/A
Power Input Fuse	2 AF	2 AF	2 AF	2 AF	
Power Consumption at 24 V d.c.	100 mA	96 mA	96 mA	120 mA	20 mA
Power Supply Monitoring Inputs	Max. input voltage: 30 V Min. input voltage for high level: 15 V Max. input voltage for low level: 8 V	N/A	N/A	Max. input voltage: 30 V Min. input voltage for high level: 15 V Max. input voltage for low level: 8 V	N/A
Power Dissipation	6 W	2.3 W	2.3 W	6 W	0.5 W
Maximum Ambient Temperature	55°C (131°F) Horizontal mounted 40°C (104°F) Vertical mounted	55°C (131°F) Horizontal mounted 40°C (104°F) Vertical mounted	55°C (131°F) Horizontal mounted 40°C (104°F) Vertical mounted	55°C (131°F) Horizontal mounted 40°C (104°F) Vertical mounted	55°C (131°F) Horizontal mounted 40°C (104°F) Vertical mounted
Electrical ModuleBus	Maximum of 12 I/O modules	N/A	N/A	Maximum of 12 single I/O modules or 6 pairs of redundant I/O modules	N/A
Optical ModuleBus	Maximum of 7 I/O clusters. Wavelength 650 nm	Local optical ModuleBus 1 and 2 with versatile link contacts, plastic or HCS. Field optical ModuleBus with ST bayonet contacts.	Local optical ModuleBus 1 and 2 with versatile link contacts, plastic or HCS. Field optical ModuleBus with SC contacts.	Maximum of 7 I/O clusters. Wavelength 650 nm	Fiber optic interface, one transmit and one receive connection for max. 10 Mbit/s. Wavelength 650 nm
Max optical cable length	Local cable: Plastic Optical Fiber (POF): Max 15 m. Hard Clad Silica (HCS): Max 200 m.	Local cable: Plastic Optical Fiber (POF): Max 15 m. Hard Clad Silica (HCS): Max 200 m. Field cable: Glass Optical fiber, multimode, 62.5/125 µm: Max 1 000 m. Glass Optical fiber, multimode, 50/125 µm: Max 100 m.	Local cable: Plastic Optical Fiber (POF): Max 15 m. Hard Clad Silica (HCS): Max 200 m. Field cable: Glass Optical fiber, single mode, 9/125 µm: Max 5 000 m.	Local cable: Plastic Optical Fiber (POF): Max 15 m. Hard Clad Silica (HCS): Max 200 m.	The module is equipped with Transmitter/Receiver for up to 10 Mbit/s. Both plastic and HCS (Hard Clad Silica) optic fiber with connectors (Agilent's, former Hewlett-Packard, Versatile Link) can be used with the TB842.
Power Output - ModuleBus	24 V max. = 1.4 A 5 V max. = 1.5 A	N/A	N/A	24 V max. = 1.4 A 5 V max. = 1.5 A	
Module termination units	N/A	N/A	N/A	TU807, TU840, TU841, TU847, TU848 or TU849	TB806, TU846 and TU847
MTU Keying code	N/A	N/A	N/A	AB	N/A
Dielectric test voltage	500 V a.c.	500 V a.c.	500 V a.c.	500 V a.c.	N/A
Rated insulation voltage	50 V	50 V	50 V	50 V	N/A
Width	58 mm (2.39 in.)	85.6 mm (3.37 in.)	85.6 mm (3.37 in.)	54 mm (2.13 in.)	17.6 mm (0.69 in.)
Depth	122 mm (4.8 in.)	58.5 mm (2.30 in.)	58.5 mm (2.30 in.)	96 mm (3.78 in.)	42.3 mm (1.67 in.)
Height	170 mm (6.7 in.)	136 mm (5.35 in.)	136 mm (5.35 in.)	119 mm (4.69 in.)	56.7 mm (2.23 in.)
Weight	300 g (0.66 lbs.)	210 g (0.46 lbs.)	210 g (0.46 lbs.)	200 g (0.44 lbs.)	90 g (0.20 lbs.)
Climatic operating conditions	0 to +55 °C (Storage -25 to +70 °C), RH=5 to 95 % no condensation, IEC/EN 61131-2 (2)				

Feature	TB820V2	TB825	TB826	TB840A	TB842
Certificates and standards ⁽³⁾	CE mark: Yes Electrical safety: IEC 61131-2, UL 508 Hazardous Location: C1 Div 2 cULus, C1 Zone 2 cULus, ATEX Zone 2 Marine certification: ABS,BV,DNV-GL,LR,RS,CCS ⁽¹⁾ Corrosive atmosphere ISA-S71.04: G3 Pollution degree: Degree 2, IEC 60664-1 Mechanical operating conditions: IEC/EN 61131-2 EMC: EN 61000-6-4 and EN 61000-6-2 Overvoltage categories: IEC/EN 60664-1, EN 50178 Equipment class: Class I according to IEC 61140; (earth protected) RoHS compliance: EN 50581:2012 WEEE compliance: DIRECTIVE/2012/19/EU				

(2) 0 to +40 °C compact MTUs on vertical DIN-rail. Approvals are issued for +5 to +55 °C.

(3) For detailed information on each module, please visit: www.800xahardwareselector.com

(*)No Marine cert. for TB826

Feature	TU807	TU840	TU841	TU846	TU847	TU848	TU849
Article number	3BSE039025R1	3BSE020846R1	3BSE020848R11	3BSE022460R1	3BSE022462R1	3BSE042558R1	3BSE042560R1
Function	Module termination unit (MTU) for single configuration of Optical ModuleBus Modem TB840/TB840A. The MTU is a passive unit having connections for power supply, a single electrical ModuleBus, one TB840/TB840A and a rotary switch for cluster address (1 to 7) setting.	Module termination unit (MTU) for redundant configuration of Optical ModuleBus Modem TB840/TB840A. The MTU is a passive unit having connections for power supply, double electrical ModuleBus, two TB840/TB840A and a rotary switch for cluster address (1 to 7) setting.	Module termination unit (MTU) for redundant configuration of Optical ModuleBus Modem TB840/TB840A, for use with non-redundant I/O. The MTU is a passive unit having connections for power supply, a single electrical ModuleBus, two TB840/TB840A and a rotary switch for cluster address (1 to 7) setting.	Module termination unit (MTU) for redundant configuration of the field communication interface CI840/CI840A and redundant I/O. The MTU is a passive unit having connections for power supply, two electrical ModuleBuses, two CI840/CI840A and two rotary switches for station address (0 to 99) settings.	Module termination unit (MTU) for redundant configuration of the field communication interface CI840/CI840A. The MTU is a passive unit having connections for power supply, electrical ModuleBus, two CI840/CI840A and two rotary switches for station address (0 to 99) settings. A ModuleBus Optical Port TB842 can be connected to TU847 via TB806.	Module termination unit (MTU) for redundant configuration of Optical ModuleBus Modem TB840/TB840A. The MTU is a passive unit having connections for two power supply (one for each modem), double electrical ModuleBus, two TB840/TB840A and a rotary switch for cluster address (1 to 7) setting.	Module termination unit (MTU) for redundant configuration of Optical ModuleBus Modem TB840/TB840A. The MTU is a passive unit having connections for two power supply, one for each modem, a single electrical ModuleBus, two TB840/TB840A and a rotary switch for cluster address (1 to 7) setting.
Cable redundancy	No	No	No	No	No	Yes	Yes
Module redundancy	No	Yes	Yes	Yes	Yes	Yes	Yes
Type	Single TB810/TB840A, Single I/O, Single Power	Redundant TB840/TB840A, Redundant I/O, Single Power	Redundant TB840/TB840A, Single I/O, Single Power	Redundant CI840/CI840A, Redundant I/O	Redundant CI840/CI840A, Single I/O	Redundant TB840/TB840A, Redundant I/O, Dual Power	Redundant TB840/TB840A, Single I/O, Dual Power
Power Input	24 V d.c. (19.2 - 30 V)	24 V d.c. (19.2 - 30 V)	24 V d.c. (19.2 - 30 V)	24 V d.c. (19.2 - 30 V)	24 V d.c. (19.2 - 30 V)	24 V d.c. (19.2 - 30 V)	24 V d.c. (19.2 - 30 V)
Hot Swap	No	No	No	No	No	No	No
Mounting	Vertical or Horizontal						
Power Consumption at 24 V d.c.	N/A	N/A	N/A	N/A	N/A	N/A	N/A
Connector	N/A	N/A	N/A	PROFIBUS: DSUB9 connector Service ports: RJ45 connector	PROFIBUS: DSUB9 connector Service ports: RJ45 connector	N/A	N/A
Acceptable wire sizes	Solid: 0.2 - 2.5 mm ² Stranded: 0.2 - 2.5 mm ² , 24 - 12 AWG Recommended torque: 0.5 Nm	Solid: 0.2 - 2.5 mm ² Stranded: 0.2 - 2.5 mm ² , 24 - 12 AWG Recommended torque: 0.5 Nm	Solid: 0.2 - 2.5 mm ² Stranded: 0.2 - 2.5 mm ² , 24 - 12 AWG Recommended torque: 0.5 Nm	Solid: 0.2 - 2.5 mm ² Stranded: 0.2 - 2.5 mm ² , 24 - 12 AWG Recommended torque: 0.5 Nm	Solid: 0.2 - 2.5 mm ² Stranded: 0.2 - 2.5 mm ² , 24 - 12 AWG Recommended torque: 0.5 Nm	Solid: 0.2 - 2.5 mm ² Stranded: 0.2 - 2.5 mm ² , 24 - 12 AWG Recommended torque: 0.5 Nm	Solid: 0.2 - 2.5 mm ² Stranded: 0.2 - 2.5 mm ² , 24 - 12 AWG Recommended torque: 0.5 Nm
Dielectric test voltage	500 V a.c.	500 V a.c.	500 V a.c.	500 V a.c.	500 V a.c.	500 V a.c.	500 V a.c.
Rated insulation voltage	50 V	50 V	50 V	50 V	50 V	50 V	50 V
Power Dissipation	N/A	N/A	N/A	N/A	N/A	N/A	N/A

Feature	TU807	TU840	TU841	TU846	TU847	TU848	TU849
Width	59 mm (1.57 in.)	124 mm (4.88 in.)	124 mm (4.88 in.)	124 mm (4.88 in.)	124 mm (4.88 in.)	124 mm (4.88 in.)	124 mm (4.88 in.)
Depth	47 mm (1.85 in.)	47 mm (1.85 in.)	47 mm (1.85 in.)	47 mm (1.85 in.)	47 mm (1.85 in.)	47 mm (1.85 in.)	47 mm (1.85 in.)
Height	186.5 mm (7.34 in.)	186.5 mm (7.34 in.)	186.5 mm (7.34 in.)	186.5 mm (7.34 in.)	186.5 mm (7.34 in.)	186.5 mm (7.34 in.)	186.5 mm (7.34 in.)
Weight	450 g (0.99 lbs.)	450 g (0.99 lbs.)	450 g (0.99 lbs.)	500 g (1.1 lbs.)	500 g (1.1 lbs.)	450 g (0.99 lbs.)	450 g (0.99 lbs.)
Climatic operating conditions	0 to +55 °C (Storage -25 to +70 °C), RH=5 to 95 % no condensation, IEC/EN 61131-2 (2)						
Certificates and standards ⁽³⁾							
Equipment class	Class I according to IEC 60536; (earth protected)	Class 1 according to IEC 60536; (earth protected)	Class 1 according to IEC 60536; (earth protected)	Class 1 according to IEC 60536; (earth protected)	Class 1 according to IEC 60536; (earth protected)	Class 1 according to IEC 60536; (earth protected)	Class 1 according to IEC 60536; (earth protected)
Protection rating	IP20 according to IEC 60529	IP20 according to IEC 60529	IP20 according to IEC 60529	IP20 according to IEC 60529	IP20 according to IEC 60529	IP20 according to IEC 60529	IP20 according to IEC 60529
CE- marking	Yes						
Electrical Safety	cULus	cULus	cULus	cULus	cULus	cULus	cULus
Hazardous location	cULus Hazardous Location Class 1 Zone 2, ATEX Zone 2	cULus Hazardous Location Class 1 Zone 2, ATEX Zone 2	cULus Hazardous Location Class 1 Zone 2, ATEX Zone 2	cULus Hazardous Location Class 1 Zone 2, ATEX Zone 2	cULus Hazardous Location Class 1 Zone 2, ATEX Zone 2	cULus Hazardous Location Class 1 Zone 2, ATEX Zone 2	cULus Hazardous Location Class 1 Zone 2, ATEX Zone 2
Marine certificates	N/A	ABS, BV, DNV-GL, LR, RS	ABS, BV, DNV-GL, LR, RS, CCS	N/A	ABS, BV, DNV-GL, LR, RS, CCS	ABS, BV, DNV-GL, LR, RS	ABS, BV, DNV-GL, LR, RS
RoHS compliance	EN 50581:2012						
WEEE compliance	DIRECTIVE/2012/19/EU						

(3) For detailed information on each module, please visit: www.800xahardwareselector.com

S800 I/O

Extended warranty for S800 I/O Hardware

Extended warranty for S800 I/O Hardware

We can offer an extended warranty for one, two, or three years in addition to normal warranty conditions for S800 I/O Hardware. See price list Extended Warranty Time.

S800 I/O

ISA-S71.04 level G3 Compliance

ISA-S71.04 level G3 Compliance

Modules are compliant to ISA-S71.04 level G3, unless explicitly stated differently.

Communication

Field Communication Interface

Field Communication Interface	Article no.
 <p>CI801 ProfiBus FCI S800 interface Including: 1 pce Power Supply Connector 1 pce TB807 Modulebus Terminator</p>	3BSE022366R1
 <p>CI801 Engineering kit SW1.3 Including: 1 pce CD with GSD file, Memory Maps and Release Note. 1 pce Reference Manual Memory Maps for CI801.</p>	3BSE038540R1300
 <p>CI840A Profibus DP-V1 Interface. For redundant communication interface two CI840A, and one TU847 or one TU846 must be ordered.</p>	3BSE041882R1
 <p>CI840 Engineering kit SW 4.0 Including: 1 pce CD with GSD file, Memory Maps and Release Notes. 1 pce Reference Manual Memory Maps for CI840.</p>	3BSE031694R4000
 <p>CI845 Ethernet FCI module Ethernet Fieldbus Communication Interface Module for connection of S800 I/O or Select I/O to Ethernet. For redundant configuration two Fieldbus Communication Interfaces CI845, two Ethernet Adapters TC810 and one TU860 or one TU865 are needed. For Select I/O High Integrity SIL3 one HI880 is needed.</p>	3BSE075853R1
 <p>TU846 MTU for CI840 For 1+1 CI840 Supporting redundant I/O. Vertical mounting of modules. Including: 1 pce Power Supply Connector 2 pcs TB807 Modulebus Terminator</p>	3BSE022460R1
 <p>TU847 MTU for CI840 For 1+1 CI840 Supporting non-redundant I/O. Vertical mounting of modules. Supporting non-redundant I/O. Including: 1 pce Power Supply Connector 1 pce TB807 Modulebus Terminator</p>	3BSE022462R1
 <p>TU860 MTU for Ethernet FCI Ethernet Fieldbus Communication Interface Module Termination Unit for connection of single or redundant S800 I/O. Supports single or redundant Ethernet Fieldbus Communication Interface Module and single or redundant Ethernet Adapter. Mounting on vertical DIN-rail.</p>	3BSE078710R1
 <p>TC810 Ethernet Adapter for Ethernet FCI Ethernet Adapter for copper media with built in 2-port switch. Hosts two RJ45 ports. Use as single or redundant.</p>	3BSE076220R1

Communication

Field Communication Interface

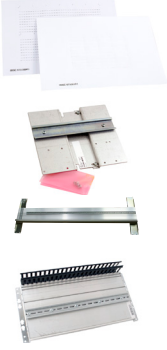
Field Communication Interface		Article no.
	Extra, Front label set FCI Sheet with 12 labels	3BSC970089R1
	Extra, Label set, item design. FCI Sheet with 40 labels.	3BSC970091R1
	Mounting kit, vertical CI801/CI840/TB840 For vertical mounting of CI801, CI840, and TB840 on a vertical DIN rail.	3BSE040749R1
	Mounting profile kit DIN rails and duct DIN rail length : 1650 mm + 210 mm (65 in.) + (8.3 in.).	3BSE049768R1
	AI-profile with DIN Rail, C. Duct, 19 in. Mounting 465 mm (19") DIN rail length 429 mm (16,9 in.)	3BSE022255R1
	AI-profile with DIN Rail, C. Duct, 24 in. Mounting 592 mm (24") DIN rail length 556 mm (21,9 in.)	3BSE022256R1

Communication

Upgrade Kit and Tool Cables

Upgrade Kit and Tool Cables		Article no.
	TK527V030 Interface cable, 3 m Used to connect a PC to CI801, CI810, CI820 and CI830 for download of software. Download to CI801 requires TK212A in addition. DE9 pin to DE9 socket. Note! This part is exempted from the scope of 2011/65/EU (RoHS) as provided in Article 2(4)(c), (e), (f) and (j) therein (ref.: 3BSE088609 – EU DECLARATION OF CONFORMITY - ABB Advant Master Process Control System)	3BSC950004R1
	TK212A Tool cable RJ45 8P8C plug Used to connect a PC to CI801, CI840 or CI840A for download of software. Download to CI801 requires a TK527V030 in addition. RJ45 (male) to Dsub-9 (female), length 3 m. RJ45 8P8C plug (with shell). Cable : UL2464 26 AWG x 8C.	3BSC630197R1
	FS801K01 Service adapter kit Including: 1 pcs Service adapter FS801 1 pcs cable TK802	3BSE038407R1

S800 I/O

S800 I/O Modules

Analog Input Modules	Article no.	
 <p>AI810 Analog Input 8 ch 0(4)..20mA, 0..10V, 12Bit, single ended. Use Module Termination Unit TU810, TU812, TU814, TU818, TU830, TU833, TU835, TU838, TU850.</p>	3BSE008516R1	
<p>AI815 Analog Input HART 8 ch 0(4)..20mA, 0(1)..5V, 12bit, single ended. Current limited transmitter power distribution. Use Module Termination Unit TU810, TU812, TU814, TU818, TU830, TU833, TU835, TU838.</p>	3BSE052604R1	
<p>AI820 Analog Input 4 ch +-20mA, 0(4)..20mA, +-10V, +-5V, 0(1)..5V, diff., 50V CMV., Rin(curr)250 Ohms, 14bit + sign. Individually galvanic isolated channels. Use Module Termination Unit TU810, TU812, TU814, TU830, TU833.</p>	3BSE008544R1	
<p>AI825 Analog Input 4 ch -20..20mA, -10..10V, 14bit + sign. Individually galvanic isolated channels. Use Module Termination Unit TU811, TU813, TU831.</p>	3BSE036456R1	
<p>AI830A Analog input RTD 8 ch Pt100, Ni100/120, Cu10, R. Use Module Termination Unit TU810, TU812, TU814, TU830, TU833.</p>	3BSE040662R1	
<p>AI835A Thermocouple/mV Input 8 ch Use Module Termination Unit TU810, TU812, TU814, TU818, TU830, TU833.</p>	3BSE051306R1	
<p>AI843 Thermocouple/mV Input S/R 8 ch Single or redundant. 16bit. Use Module Termination Unit TU818, TU830, TU833, TU842, TU843, TU852.</p>	3BSE028925R1	
<p>AI845 Analog Input S/R HART 8 ch 0(4)..20mA, 0(1)..5V, 12bit, single ended. Current limited transmitter power distribution. Advanced on-board diagnostics. HART support. Use Module Termination Unit TU810, TU812, TU814, TU818, TU830, TU833, TU835, TU838, TU844, TU845, TU854</p>	3BSE023675R1	
<p>AI890 Analog Input IS 8 ch 0(4)..20mA single ended. Intrinsic Safety Interface. Use Module Termination Unit TU890 or TU891.</p>	3BSC690071R1	
<p>AI893 Analog Input TC/RTD IS 8 ch For TC and RTD sensors. Intrinsic Safety Interface. Use Module Termination Unit TU890 or TU891.</p>	3BSC690141R1	
<p>AI895 Analog Input IS HART 8 ch 4..20mA single ended. Intrinsic Safety Interface and HART. Use Module Termination Unit TU890 or TU891.</p>	3BSC690086R1	

S800 I/O

S800 I/O Modules

Analog Output Modules	Article no.	
 <p>AO810V2 Analog Output 8 ch 0(4)...20mA, 14bit RLmax 500/850 Ohms. Use module Termination Unit TU810, TU812, TU814, TU830 or TU833.</p>	3BSE038415R1	
<p>AO815 Analog Output HART 8 ch 1x8 ch. 4...20mA, 12bit, RLmax 750 ohm. Use Module Termination Unit TU810, TU812, TU814, TU830 or TU833.</p>	3BSE052605R1	
<p>AO820 Analog Output 4 ch +-20mA, 0(4)...20mA, +-10V, 12bit+sign. Individually galvanic isolated channels. RL max 500 Ohms. Use Module Termination Unit TU810, TU812, TU814, TU830, TU833.</p>	3BSE008546R1	
<p>AO845A Analog Output S/R HART 8 ch (0) 4...20mA, 12bit, RLmax 750 ohm. Single or redundant. Loop supervised DI function. Use Module Termination Unit TU810, TU812, TU814, TU830, TU833, TU842, TU843, TU852.</p>	3BSE045584R1	
<p>AO890 Analog Output IS 8 ch 0(4)...20mA. RL max 750 ohm. Intrinsic Safety Interface. Use Module Termination Unit TU890 or TU891.</p>	3BSC690072R1	
<p>AO895 Analog Output IS HART 8 ch 0(4)...20mA. RL max 750 ohm. Intrinsic Safety Interface and HART. Use Module Termination Unit TU890 or TU891.</p>	3BSC690087R1	

S800 I/O

S800 I/O Modules



Digital Input Modules	Article no.	
DI810 Digital Input 24V 16 ch Isolated in two groups of 8 channels. Use Module Termination Unit TU810, TU812, TU814, TU818, TU830, TU833, TU838, TU850.	3BSE008508R1	
DI811 Digital Input 48V 16 ch Isolated in two groups of 8 channels. Use Module Termination Unit TU810, TU812, TU814, TU818, TU830, TU833, TU838, TU850.	3BSE008552R1	
DI814 Digital Input 24V Current 16 ch Isolated in two groups of 8 channels. Current sourcing. Use Module Termination Unit TU810, TU812, TU814, TU830, TU833, TU838.	3BUR001454R1	
DI818 Digital Input 24V 32 ch Isolated in two groups of 16 channels. Use Module Termination Unit TU818, TU819, TU830.	3BSE069052R1	
DI820 Digital Input 120V a.c. 8 ch Individually galvanic isolated channels. Use Module Termination Unit TU811, TU813, TU831, TU839, TU851.	3BSE008512R1	
DI821 Digital Input 230V 8 ch Individually galvanic isolated channels. Use Module Termination Unit TU811, TU813, TU831, TU839, TU851.	3BSE008550R1	
DI825 Digital Input 125V SOE 8 ch Individually galvanic isolated channels. Use Module Termination Unit TU811, TU813, TU831.	3BSE036373R1	
DI828 Digital Input, 120V 16 ch Individually galvanic isolated channels. Use Module Termination Unit TU851.	3BSE069054R1	
DI830 Digital Input 24V SOE 16 ch Isolated in two groups of 8 channels. Use Module Termination Unit TU810, TU812, TU814, TU818, TU830, TU833, TU838, TU850.	3BSE013210R1	
DI831 Digital Input 48V SOE 16 ch Isolated in two groups of 8 channels. Use Module Termination Unit TU810, TU812, TU814, TU818, TU830, TU833, TU838, TU850.	3BSE013212R1	
DI840 Digital Input 24V S/R 16 ch. Single or redundant. Advanced On-Board diagnostics. Use Module Termination Unit TU810, TU812, TU814, TU818, TU830, TU833, TU838, TU842, TU843, TU852.	3BSE020836R1	
DI890 Digital Input IS 8 ch Intrinsic Safety Interface. Individually galvanic isolated channels. Use Module Termination Unit TU890 or TU891.	3BSC690073R1	

S800 I/O

S800 I/O Modules

Digital Output Modules		Article no.
	DO810 Digital Output 24 V 16 ch Isolated in two groups of 8 channels. 0.5A, Short circuit proof. Use Module Termination Unit TU810, TU812, TU814, TU830, TU833.	3BSE008510R1
	DO814 Digital Output current 16 ch Isolated in two groups of 8 channels. 0,5A , shortcut circuit proof. Current sinking. Use Module Termination Unit TU810, TU812, TU814, TU830, TU833, TU838.	3BUR001455R1
	DO815 Digital Output 24V 8ch Isolated in two groups of 4 channels. 2.0A short circuit proof. Use Module Termination Unit TU810, TU812, TU814, TU830, TU833.	3BSE013258R1
	DO818 Digital Output 24V 32 ch Isolated in two groups of 16 channels. 0.5A, Short circuit proof. Use Module Termination Unit TU818, TU819, TU830.	3BSE069053R1
	DO820 Digital Output 8 ch 24-230V a.c./d.c. 3A, $\cos \phi > 0.4$, d.c. 42W. Individually galvanic isolated channels. Use Module Termination Unit TU811, TU813, TU831, TU836, TU837, TU851.	3BSE008514R1
	DO821 Digital Output Relay 8 ch 24-230V a.c./d.c.. 3A, $\cos \phi > 0.4$, d.c. 42W, normal closed. Individually galvanic isolated channels. Use Module Termination Unit TU811, TU813, TU831, TU836, TU837, TU851.	3BSE013250R1
	DO828 Digital Output Relay 16 ch Individually galvanic isolated channels. 5-250V a.c and 5-125V d.c, max 2A. Use Module Termination Unit TU851.	3BSE069055R1
	DO840 Digital Output S/R 16 ch Isolated in two groups of 8 channels. Single or redundant. 0.5A. Advanced On-board diagnostics. Use Module Termination Unit TU810, TU812, TU814, TU830, TU833, TU842, TU843, TU852.	3BSE020838R1
	DO890 Digital Output IS 4 ch Intrinsic Safety Interface. Individually galvanic isolated channels. Use Module Termination Unit TU890 or TU891.	3BSC690074R1

S800 I/O

Pulse Counting Modules

Pulse Counting Modules		Article no.
	DP820 Pulse Counter RS-422 2 ch bidirectional pulse counters and frequency measurement, current, 5V, (12v), 24V. 1,5MHz Rated isol 50V Use Module Termination Unit TU810, TU812, TU814, TU830, TU833.	3BSE013228R1
	DP840 Pulse Counter S/R 8 ch Pulse Counter or Frequency Measurement Module. Redundant or single. 0.5Hz - 20kHz. Use Module Termination Unit TU810, TU812, TU814, TU818, TU830, TU833, TU842, TU843, TU844, TU845, TU852, TU854.	3BSE028926R1



S800 I/O

Label sets for I/O Modules

Label sets for I/O Modules	Article no.	
	Transparent film fronts Set of 12 transparent plastic film fronts. To be used with ordinary paper quality.	3BSE072159R1
	White colored plastic coated paper One sheet of size A4. Original paper quality. No need to use transparent films.	3BSE072160R1
	Yellow colored plastic coated paper One sheet of size A4. Original paper quality. No need to use transparent films. To be used with DI880, DO880, AI880A.	3BSE072161R1

S800 I/O

High Integrity I/O Modules

High Integrity I/O Modules	Article no.	
 	The modules can only be connected to a AC800M controller PM857, PM863, PM865 or PM867. Direct connection to the modulebus and via the optical modulebus via TB840 (not TB820).	
	AI88A Analog Input HI S/R HART 8 ch (0) 4..20mA. 12bit. HART communication. Single or redundant. High integrity, certified for SIL3. Requires configuration according to Safety Manual. Loop supervised DI function. Use Module Termination Unit TU834, TU844, TU845, TU854.	3BSE039293R1
	DI880 Digital Input HI S/R 16 ch 24V d.c. inputs. High integrity, certified for SIL3. Single or redundant. Requires configuration according to Safety Manual. Use Module Termination Unit TU810, TU812, TU814, TU818, TU830, TU833, TU838, TU842, TU843, TU852.	3BSE028586R1
	DO880 Digital Output HI S/R 16 ch 24V d.c., 0,5A Outputs. High integrity, certified for SIL3. Single or redundant. Requires configuration according to Safety Manual. Use Module Termination Unit TU810, TU812, TU814, TU830, TU833, TU842, TU843, TU852.	3BSE028602R1
	SS823 Voting Device Required in a High Integrity 800xA system. One per power supply unit, also at redundant configurations. Input d.c. 24 V. Dual 24 V to single 24 V, 20A. DIN rail mounted.	3BSE038226R1













S800 I/O

Module Termination Units

Module Termination Units	Article no.	
 <p>TU805K01 Termination Units 2- or 3-wire Includes 10 pcs of Termination Unit TU805 for DI801 and DO801.</p>	3BSE035990R1	
 <p>TU810V1 Compact MTU, 50V Compact Module Termination Unit 2x8 signal terminals.</p>	3BSE013230R1	
 <p>TU811V1 Compact MTU, 250V Compact Module Termination Unit 1x8 signal terminals.</p>	3BSE013231R1	
 <p>TU812V1 Compact MTU, 50V, D-sub Compact Module Termination Unit with 25 pin D-sub connector, rated isol. 50V. D-sub (female) connector is not enclosed.</p>	3BSE013232R1	
 <p>TU813 Compact MTU, 250V Crimped snap-in connectors.</p>	3BSE036714R1	
 <p>TU814V1 Compact MTU, 50V, snap-in con. Compact Module Termination Unit 2x8 Signal terminals for crimped snap-in connectors. Detachable (pluggable) connectors are enclosed.</p>	3BSE013233R1	
 <p>TU818 Compact MTU, 50V Compact Module Termination Unit with 1x32 (and 2x16) signal terminals.</p>	3BSE069209R1	
 <p>TU819 Compact MTU, 50V Compact Module Termination Unit with 2x25 pin D-sub connector, D-sub (female) connector is not enclosed.</p>	3BSE068891R1	
 <p>TU830V1 Extended MTU, 50V. Extended Module Termination Unit 2x16 signal terminals.</p>	3BSE013234R1	
 <p>TU831V1 Extended MTU, 250V Extended Module Termination Unit 2x8 signal terminals.</p>	3BSE013235R1	
 <p>TU833 Extended MTU, 50V 2x16 signal terminals, Spring-cage terminals.</p>	3BSE038726R1	
<p>TU834 Extended MTU, 50V Used with AI880A. Shunt Stick not included.</p>	3BSE040364R1	
<p>TU835V1 Extended MTU, 50V, Fused Extended Module Termination Unit 8 fused power outlets, 8 signal terminals.</p>	3BSE013236R1	
<p>TU836V1 Extended MTU, 250V, Fused Extended Module Termination Unit 2x4 fused signals, 2x4 return terminals, 2x2 L 2x2N terminals.</p>	3BSE013237R1	
<p>TU837V1 Extended MTU, 250V, Fused Extended Module Termination Unit 8x1 fused isol. signals, 8x1L terminals, 2x6 N terminals.</p>	3BSE013238R1	
<p>TU838 Extended MTU, 50V. Extended Module Termination Unit 2x4 fused transducer power outlets, 16 signal terminals, 2x4 return terminals, 2x2 L+, 2x2 L- terminals. Module is mounted horizontally.</p>	3BSE008572R1	
<p>TU839 Extended 250V Extended Module Termination Unit, 2x8 signal terminals 2x4 fused sensor power.</p>	3BSE046966R1	
<p>TU842 Redundant MTU, 50V. Used with redundant I/O. Horizontal DIN rail mounting.</p>	3BSE020850R1	
<p>TU843 Redundant MTU, 50V Used with redundant I/O. Vertical DIN rail mounting.</p>	3BSE021443R1	

S800 I/O and S800L I/O

Module Termination Units

Module Termination Units	Article no.	
 <p>TU844 Redundant MTU, 50V Used with redundant I/O. Horizontal DIN rail mounting. Shunt Stick not included.</p>	3BSE021445R1	
 <p>TU845 Redundant MTU, 50V Used with redundant I/O. Vertical DIN rail mounting. Shunt Stick not included.</p>	3BSE021447R1	
 <p>TU850 Extended MTU, 50V 2x8 signal terminals and 2x8 disconnectable current limited sensor/transmitter outlet power terminals.</p>	3BSE050930R1	
 <p>TU851 Extended MTU, 250V Extended Module Termination Unit with 2x16 signal terminals.</p>	3BSE068782R1	
 <p>TU852 MTU, Redundant, 50V Used with redundant I/O. Horizontal DIN rail mounting. With 2x25 pin D-sub connector.</p>	3BSE069964R1	
 <p>TU854 MTU, Redundant, 50V Used with redundant I/O. Horizontal DIN rail mounting. With 1x25 pin D-sub connector. Shunt Stick not included.</p>	3BSE069966R1	
 <p>TU890 IS MTU Module Termination Unit with Intrinsic Safety Interface, 3x9 signal terminals.</p>	3BSC690075R1	
 <p>TU891 non-IS MTU Module Termination Unit for 3x9 signal terminals. For non Intrinsic Safety.</p>	3BSC840157R1	
 <p>TY801K01 8pcs Shunt Stick 125 + 125 ohms shunt. Used for AI845 and AI880A on TU834, TU844, TU845, TU854.</p>	3BSE023607R1	
 <p>TY804K01 8pcs Shunt Stick 1000 ohms shunt. Used for DP840 on TU844, TU845, TU854.</p>	3BSE033670R1	
 <p>TY805K01 8pcs Shunt Stick 125 + 125 ohms shunt with current limitation on transmitter power. Used for AI845 and AI880A on TU834, TU844, TU845, TU854.</p>	3BSE081160R1	
 <p>TY820K01 10pcs Temperature Sensor TY820 is a temperature sensor with a PT 100 element. Used with AI835/AI835A and AI843 to measure cold junction Temperature.</p>	3BSE056980R1	

S800L I/O

S800L I/O Modules

Analog Input Modules		Article no.
	AI801 Analog input 8ch, 0(4)...20mA, 12bit, single ended.	3BSE020512R1
Analog Output Modules		Article no.
AO801 Analog output 8ch, 0(4)...20mA, 12 bit, RLmax 850 Ohm.		3BSE020514R1
Digital Input Modules		Article no.
DI801 Digital Input 24V 16ch Current sink.		3BSE020508R1
DI802 Digital Input 120V 8ch. Individually galvanic isolated channels.		3BSE022360R1
DI803 Digital Input 230V 8ch. Individually galvanic isolated channels.		3BSE022362R1
Digital Output Modules		Article no.
DO801 Digital Output 24V 16ch 0.5A		3BSE020510R1
DO802 Digital Output Relay 8ch 24-230V, a.c./d.c. Individually galvanic isolated channels.		3BSE022364R1

S800L I/O

Label sets for S800L I/O Modules

Label sets for S800L I/O Modules		Article no.
	Label Set S800L, 16ch Text colour: Black, Text style: Helv. reg., Text height: 2mm, Material: Polyesterfilm Xeroperm t=0,12 Sheet with 12 labels for 16 channels I/O modules.	3BSE019419R1
	Label Set S800L, 8ch Text colour: Black, Text style: Helv. reg., Text height: 2mm, Material: Polyesterfilm Xeroperm t=0,12 Sheet with 12 labels for 8 channels I/O modules.	3BSE019419R2

S800 I/O and S800L I/O

ModuleBus Communication Parts

ModuleBus Communication Parts	Article no.	
	TB805 Bus Outlet Modulebus extension cable adaptor D-sub 25, female. One required per extension cable TK801.	3BSE008534R1
	TB845, Dual Modulebus outlet Modulebus extension cable adaptor two D-sub, female. Two TK801 cables for redundancy.	3BSE021437R1
	TB806 Bus Inlet Modulebus extension cable adaptor D-sub 25, male. One required per extension cable TK801.	3BSE008536R1
	TB846, Dual Modulebus inlet Modulebus extension cable adaptor two D-sub, male. Two TK801 cables for redundancy.	3BSE021439R1
	TK801V003 Cable, 0.3m Modulebus Extension Shielded Cable 0.3m D-sub 25, male-female.	3BSC950089R1
	TK801V006 Cable, 0.6m Modulebus Extension Shielded Cable 0.6m D-sub 25, male-female.	3BSC950089R2
	TK801V012 Cable, 1.2m Modulebus Extension Shielded Cable 1.2m D-sub 25, male-female.	3BSC950089R3
	TB807 Modulebus terminator Terminator for Modulebus.	3BSE008538R1
	TB820V2 Modulebus Cluster Modem Optical cluster modem for non redundant operation. Including: 1 pce Power Supply Connector 1 pce TB807 Modulebus Terminator	3BSE013208R1
	TB825 Optical Media Converter Multi Mode Short to long distance optical fiber conversion. For modulebus communication up to 1000 m.	3BSE036634R1
	TB826 Optical Media Converter Single Mode Short to long distance optical fiber conversion. For modulebus communication up to 5000 m, for S800 I/O HI up to 20000 m.	3BSE061637R1
	TB840A Modulebus Cluster Modem Optical cluster modem for 1+1 redundant operation.	3BSE037760R1
	TB842 Modulebus Optical Port Used together with CI801 and CI840, connected via TB806 or TB846.	3BSE022464R1
	TU807 Termination Unit for TB840/TB840A For single modulebus I/O. Including: TB807	3BSE039025R1
	TU840 Termination Unit for 1+1 TB840. Support for redundant I/O Including: 1 pce Power Supply Connector 2 pcs TB807 Modulebus Terminator	3BSE020846R1
	TU841 Termination unit for 1+1 TB840. Support for non-redundant I/O. Including: 1 pce Power Supply Connector 1 pce TB807 Modulebus Terminator	3BSE020848R1

S800 I/O and S800L I/O

ModuleBus Communication Parts

ModuleBus Communication Parts	Article no.		
	TU848 Termination Unit for 1+1 TB840 MTU with individual power supply. Support for redundant I/O. Including: 1 pcs Power Supply Connector 2 pcs TB807 Modulebus Terminator	3BSE042558R1	
	TU849 Termination Unit for 1+1 TB840 MTU with individual power supply. Support for non-redundant I/O. Including: 1 pcs Power Supply Connector 1 pcs TB807 Modulebus Terminator	3BSE042560R1	
	TK811V015 POF Cable, 1.5m, Duplex 1.5 m latching duplex connector Duplex plastic fibre	3BSC950107R1	
	TK811V050 POF Cable, 5m, Duplex 5 m latching duplex connector Duplex plastic fibre	3BSC950107R2	
	TK811V150 POF Cable, 15m, Duplex 15 m latching duplex connector Duplex plastic fibre	3BSC950107R3	
	TK812V015 POF Cable, 1.5m, Simplex 1.5 m latching connector Simplex plastic fibre	3BSC950118R1	
	TK812V050 POF Cable, 5m, Simplex 5.0 m latching connector Simplex plastic fibre	3BSC950118R2	
	TK812V150 POF Cable, 15m, Simplex 15 m latching connector Simplex plastic fibre	3BSC950118R3	

S800 I/O Power supplies and voters selection guide

Feature	SD822Z	SD831	SD832	SD833	SD834	SS822Z	SS832	SS823	SD853	SD854
Rated output current	5 A	3 A	5 A	10 A	20 A	20 A	10 A (20 A in parallell operation)	20 A	10 A	20 A
Rated output power	120 W	72 W	120 W	240 W	480 W	-	-	-	240 W	480 W
Rated output voltage	d.c. 24 V	d.c. 24 V	d.c. 24 V	d.c. 24 V	d.c. 24 V	-	-	-	24 V d.c.	24 V d.c.
Rated input power	280 VA 135 W	134/143 VA	240/283 VA	447/514 VA	547/568 VA	500 W	240 W (480 W in parallell operation)	500 W		
Mains/input voltage, nominal	115/230 V a.c. 225-250 V d.c.	100-240 V a.c. 110-300 V d.c.	100-120 V a.c. 200-240 V a.c. Auto-select input	100-120 V a.c. 200-240 V a.c. Auto-select input	100-240 V a.c. 110-150 V d.c.	2x24 V d.c.	2x24 V d.c (1x24 V d.c in parallell operation)	1x24 V d.c.	100-240 V a.c. 110-150 V d.c.	100-240 V a.c. 110-150 V d.c.
Mains voltage variation allowed	85 - 110%	90-264 V a.c. 88-375 V d.c.	90-132 V a.c. 180-264 V a.c.	90-132 V a.c. 180-264 V a.c.	85-276 V a.c. 88-375 V d.c.	-	-	-	85-264 V a.c. 88-180 V d.c.	85-264 V a.c. / 88-180 V d.c.
Primary peak inrush current at power on	Typ 15 A	<28/<54 A	<10 A	<10 A	<13 A	-	-	-	6 A / 9 A peak	10 A / 4.5 A peak
Applications	SELV and PELV	SELV and PELV	SELV and PELV	SELV and PELV	SELV and PELV	-	-	-	SELV and PELV	SELV and PELV
Load sharing	Two in parallell	-	-	-	Parallell connection	Two in parallell	Two in parallell	Yes	-	Parallell connection
Power Factor (at rated output power)		0.61/0.56	0.56/0.47	0.59/0.51	0.95/0.90	-	-	-	0.99/0.97	0.99/0.95
Heat dissipation	13 W	10/8 W	14/13 W	24/22 W	40/32 W	10 W at 20 A and 2,5 W at 5 A	9 W (18 W)	24 W at 20 A and 6 W at 5 A	16.4 W / 12.1 W, 120/230 V a.c.	29.6/22.1 W, 120/230 V a.c.
Efficiency factor (%)	88	88/89.8	89.4/90.2	91/91.6	92.4/93.9	-	-	-	93.6/95.2	94.2/95.6
Output voltage regulation at max. current	+/- 2%	< 50 mV / < 100 mV	< 70 mV / < 100 mV s	< 70 mV / < 100 mV	< 10 mV / < 100 mV	0,5 V lower than input	0.85 V lower than input	1.2 V lower than input	< 50 mV	< 100 mV
Ripple (peak to peak)	< 50 mV	< 50 mV	< 50 mV	< 50 mV	< 100 mV	-	-	-	< 50 mV	50 mV
Secondary voltage holdup time at mains blackout	> 20 ms	29/120 ms	80/78 ms	46/47 ms	32/51 ms	-	-	-	37 ms	32 ms
Maximum output current (min)	10 A	3.3 A	6 A At ambient temp < 45 °C	12 A At ambient temp < 45 °C	30 A < 4 s	35 A (Overload)	25 A (Overload)	35 A (Overload)	12 A At ambient temp < 45 °C	24 A At ambient temp < 45 °C
Maximum ambient temperature	60 °C	60 °C	60 °C	60 °C	60 °C	60 °C	60 °C	55 °C	70 °C	70 °C
Primary: Recommended external fuse ⁽¹⁾	10 A	10-20 A	10-20 A	10-20 A	10-20 A	-	-	-	10-20 A	10-20 A
Secondary: Short circuit	< 10 A	< 8 A	< 14 A	< 18 A	< 40 A	-	-	-	30 A for < 12 ms	60 A for < 12 ms
Secondary: Over-Voltage protection	29 V	< 39 V	< 39 V	< 39 V	< 37 V	-	-	< 30 V	Max 32 V	Max 32 V
Class of protection	I PE (Protective Earth) connection required					-	-	-	I PE (Protective Earth) connection required	
Protection rating	IP20 according to IEC60529									

S800 I/O Power supplies and voters selection guide



Feature *	SD822Z	SD831	SD832	SD833	SD834	SS822Z	SS832	SS823	SD853	SD854
Width	65 mm (2.56 in.)	32 mm (1.26 in.)	32 mm (1.26 in.)	60 mm (2.36 in.)	82 mm (3.23 in.)	50 mm (1.97 in.)	32 mm (1.26 in.)	116 mm (4.6 in.)	39 mm (1.53 in.)	48 mm (1.88 in.)
Depth	110 mm (4.3 in.)	102 mm (4.02 in.)	117 mm (4.61 in.)	117 mm (4.61 in.)	127 mm (5.0 in.)	110 mm (4.3 in.)	117 mm (4.61 in.)	145 mm (5.8 in.) including connector	117 mm (4.60 in.)	127 mm (5.00 in.)
Height	125 mm (4.9 in.)	124 mm (4.88 in.)	124 mm (4.88 in.)	124 mm (4.88 in.)	124 mm (4.88 in.)	125 mm (4.9 in.)	125 mm (4.9 in.)	132 mm (5.3 in.)	124 mm (4.88 in.)	124 mm (4.88 in.)
Mounting spacing Width mm	15 mm (0.59 in.)	15 mm (0.59 in.)	15 mm (0.59 in.)	15 mm (0.59 in.)	15 mm (0.59 in.)	15 mm (0.59 in.)	15 mm (0.59 in.)	15 mm (0.6 in.)	15 mm (0.59 in.)	15 mm (0.59 in.)
Mounting spacing Height mm	25 mm (1 in.)	40 mm (1.57 in.)	40 mm (1.57 in.)	40 mm (1.57 in.)	40 mm (1.57 in.)	25 mm (1 in.)	25 mm (1 in.)	25 mm (1.2 in.)	40 mm (1.57 in.)	40 mm (1.57 in.)
Weight (lbs.)	620 g (1.4 lbs)	430 g (0.9 lbs.)	500 g (1.1 lbs.)	700 g (1.5 lbs.)	1200 g (2.6 lbs.)	630 g (1.4 lbs)	350 g (0.77 lbs.)	870 g (1.9 lbs.)	600 g (1.32 lbs)	830 g (1.83 lbs)
Corrosive atmosphere ISA-S71.04	G3	G2	G2	G2	G2	G3	G2	G3	G3	G3
CE mark	Yes	Yes	Yes	Yes	Yes	Yes	Yes	Yes	Yes	Yes
RoHS compliance	EN 50581:2012									
WEEE compliance	DIRECTIVE/2012/19/EU									
El. safety, Haz loc, C1 Zone 2	No	No	No	No	No	No	No	No	Yes	Yes
El. safety, Haz loc, C1 Div 2	No	No	No	No	Yes	No	No	No	Yes	No
Electrical safety	IEC 61131-2, UL 508, EN 50178 (Note! UL 508 not valid for SS823)								IEC 60950-1	
Pollution degree	Degree 2, IEC 60664-1									
Mechanical operating conditions	EN 61131-2									
EMC	EN 61000-6-4 and EN 61000-6-2									
Over voltage Categories	Over-voltage Category III (IEC/EN 60664-1)									
RoHS compliance	DIRECTIVE/2011/65/EU (EN 50581:2012)									
WEEE compliance	DIRECTIVE/2012/19/EU									

⁽¹⁾ Microcircuit Breaker (MCB), Characteristic B

* For detailed information on each module, please visit: www.800xAhardwareselector.com

S800 I/O

Power Supply

Power Supply	Article no.	
 <p>SD822Z Power Supply, 5A Input 115/230V a.c. switch selectable, output 24V d.c., 5A. If redundant power application is required connect to SS822Z voting unit. DIN rail mounted.</p>	3BSC610054R1	
<p>SD831 Power Supply, 3A Input a.c. 100-240 V or d.c. 110-300 V. Output d.c. 24 V 3A. If redundant power application is required connect to SS8XX voting unit. DIN rail mounted. G2 compliant.</p>	3BSC610064R1	
<p>SD832 Power Supply, 5A Input a.c. 100-120/200-240 V. Output d.c. 24 V 5A, auto-select input. If redundant power application is required connect to SD8XX voting unit. DIN rail mounted. G2 compliant.</p>	3BSC610065R1	
<p>SD833 Power Supply, 10A Input a.c. 100-120/200-240 V, auto-select input. Output d.c. 24 V 10A. If redundant power application is required connect to SD8XX voting unit. DIN rail mounted. G2 compliant.</p>	3BSC610066R1	
<p>SD834 Power Supply, 20A Input a.c. 100-240 V or d.c. 110-150 V. Output d.c. 24 V 20A. If redundant power application is required connect to SS8XX voting unit. DIN rail mounted. G2 compliant.</p>	3BSC610067R1	
<p>SD853 Power Supply 10A 10A Power Supply Module. Input AC 100-240V. Input DC 110-150V. Output DC 24-28V. Mounting on horizontal DIN rail. Width 39 mm.</p>	3BSE088188R1	
<p>SD854 Power Supply 20A 20A Power Supply Module. Input AC 100-240V. Input DC 110-150V. Output DC 24-28V. Mounting on horizontal DIN rail. Width 48 mm.</p>	3BSE088189R1	
<p>SS822Z Power Voting Unit With dual 24V d.c. 20A inputs, single 24V d.c. 20A output. Each power input supervised. Used if redundant power supply is required. For use with power supply SD822Z. DIN rail mounted.</p>	3BSC610055R1	
<p>SS832 Power Voting Unit Input d.c. 24 V. Dual 24 V to single 24 V, 2x10A. DIN rail mounted. G2 compliant.</p>	3BSC610068R1	
 <p>Mains Breaker Kit for DIN Rail 115/230V a.c. with input terminals, breaker and 3 fused (6.3A). Double output terminals. Width = 102,5 mm.</p>	3BSE022262R1	

S900 Remote I/O System

The S900 remote I/O system communicates with System 800xA or other controllers over PROFIBUS. Suitable for applications in the chemical, pharmaceutical, oil and gas industries, S900 I/O can be installed in hazardous areas, thereby reducing marshalling and wiring costs.

Further maintenance savings can be achieved through S900's extended diagnostics and the use of HART®-compliant field devices.

Three series of S900 I/O are available:

- S-series for applications in Zone 1 hazardous areas
- B-series for applications in Zone 2 hazardous areas
- N-series for applications in non hazardous areas

Additional solutions for specific applications are available:

- Field housing - for wall mounting and field mounting in Zone 1 installations with system approval fully certified in accordance with ATEX. The high-grade steel housing is prepared for wall-mounting with facility for insulated screen rails or terminals.
- CB220 compact box - S900 in compact form (with up to 4 I/O modules). This variant is suitable for use in applications such as temperature multiplexers and solenoid valve circuits.

The S900 components are based on a passive backplane suitable for mounting on a DIN rail or directly in a sub-distribution board. The passive backplane includes internal bus communication, terminals for field circuits, communication, and power supply. The function modules are plugged into the backplane in their appropriate slots. The redundant backplane has two slots for power supply units, two slots for communication interfaces, and 16 slots for function modules. Digital function modules have up to 8 channels, analog modules up to four. Therefore, when using a redundant backplane, 128 digital or 64 analog channels can be connected per station. In the case of the S and B series, up to ten S900 stations can be connected on a single fieldbus line.

Key S900 benefits include:

- Intrinsically safe - can be installed in Zone 1 and Zone 2 areas.
- Good price/performance ratio because external barriers have been removed and costs are reduced in terms of cabling, installation, hardware, and maintenance.
- Easy configuration using either FDT/DTM or GSD files, allowing easy integration with System 800xA process control systems.
- High availability of the plant thanks to redundancy and hot-swap capability of all components during operation.

Series	Assembly	Field devices / signals	Hazardous area approval
S series	In Zone 1	In Zones 2, 1 and 0 (intrinsically safe signals)	ATEX Zone 1 (Blue TU921S)
B series	In Zone 2	In Zones 2, 1 and 0 (intrinsically safe signals)	ATEX Zone 2 (Blue TU921B)
N series	In safe areas	In safe areas	No * (Black TU921N)

* Field devices mounted in Zone 1/Zone 0 can be connected to N-Series with additional IS barriers; a benefit of IS modules of S- and B-Series.





TU921B for ATEX Zone 2

	NAMUR inputs	Binary 24 V	Binary 48 V	Binary 110 V	Binary 230 V	Binary Relay	Analog Unipolar	Analog Bipolar	Temperature RTD	Temperature T/C	SOE	HART	Intrinsic safety	Redundant	High integrity
I/O Features S900															
Digital I/O modules															
DX910S,B,N*	•												S,B		
Digital output modules															
DO910S,B,N*													S,B		
DO930N		•													
Pulse input modules															
DP910S,B,N*					•								S,B		
Analog input modules															
AI910S,B,N*						•							S,B		
AI930S,B,N*						•						•	S,B		
AI931S,B,N*						•						•	S,B		
AI950S,B,N*								•	•				S,B		
Analog output modules															
AO910S,B,N*						•							S,B		
AO920S,B,N*						•							S,B		
AO930S,B,N*						•						•	S,B		

* For details about S900 I/O please refer to the S900 catalog, document number 3BDD010420.

S900 Remote I/O System

Ex zone 1 system components

Termination Unit	Article no.
 <p>TU921S Redundant Termination Unit (TU16R-Ex) For 16 I/O-modules Redundant communication and power (Delivery includes CD910)</p>	3KDE175111L9210
Power Supply	Article no.
 <p>SA920S Power Supply For 24 V DC Do not mix SA910S with SA920S for redundancy (observe Release Notes)</p>	3BDH000602R1
Communication Interface	Article no.
 <p>CI920AS Communication Interface V 2.1 (CIPBA-Ex) Use only CI920AS with the same firmware for redundancy for PROFIBUS DP-V1 (observe Release Notes).</p>	3BDH000690R1

S900 Remote I/O System

Ex zone 1 system components





Digital Input or Output		Article no.
	DX910S Digital Input or Output (DIO8-Ex) Input for dry contact or NAMUR initiator Output for low power Intrinsic Safe valves.	3KDE175311L9100
	DO910S Digital Output (DO4-Ex) Output for Intrinsic Safe valves	3KDE175321L9100
	DP910S Frequency Input (FI2-Ex) Input for dry contact or NAMUR initiator	3KDE175361L9100

Analog Input		Article no.
	AI910S Analog input (AI4-Ex) Transmitter power supply, 4...20 mA	3KDE175511L9100
	AI930S Analog Input, HART (AI4H-Ex) Transmitter power supply, 4...20 mA	3KDE175511L9300
	AI931S Analog Input, HART (AI4H-Ex) Passive input, 0/4...20 mA	3KDE175511L9310
	AI950S Temperature (TI4-Ex) Pt100, Pt1000, Ni100 in 2-/3-/4- Technology thermocouples type B, E, J, K, L, N, R, S, T Isolated inputs channel by channel.	3KDE175521L9500

Analog Output		Article no.
	AO910S Analog output (AO4-Ex) Output 0/4...20 mA	3KDE175531L9100
	AO920S Analog output, isolated (AO4I-Ex) Output 0/4...20 mA Isolated outputs channel by channel	3KDE175531L9200
	AO930S Analog output HART (AO4H-Ex) Output 0/4...20 mA	3KDE175531L9300

S900 Remote I/O System

Ex zone 2 system components

Termination Unit	Article no.	
 <p>TU921B Redundant Termination Unit (TU16R-B) For 16 I/O-modules Redundant communication and power (Delivery includes CD910)</p>	3KDE175112L9210	
Power Supply	Article no.	
 <p>SA920B Power Supply For 24 V DC The power supply filter type BP901S is not required SA920B is the functional replacement for SA910B do not mix SA910B with SA920B for redundancy (observe Release Notes)</p>	3BDH000601R1	
Communication Interface	Article no.	
 <p>CI920AB Communication Interface V 2.1 (CIPBA-B) Use only CI920AB with the same firmware for redundancy for PROFIBUS DP-V1 (observe Release Notes).</p>	3BDH000691R1	
Digital Input or Output	Article no.	
 <p>DX910B Digital Input or Output (DIO8-B) Input for dry contact or NAMUR initiator Output for low power I.S. valves</p> <p>DO910B Digital Output (DO4-B) Output for I.S. valves</p> <p>DP910B Frequency Input (FI2-B) Input for dry contact or NAMUR initiator</p>	<p>3KDE175312L9100</p> <p>3KDE175322L9100</p> <p>3KDE175362L9100</p>	

S900 Remote I/O System





Ex zone 2 system components

Analog Input		Article no.
	AI910B Analog input (AI4-B) Transmitter power supply, 4...20 mA	3KDE175512L9100
	AI930B Analog Input, HART (AI4H-B) Transmitter power supply, 4...20 mA	3KDE175512L9300
	AI931B Analog Input, HART (AI4H-B) Passive input, 0/4...20 mA	3KDE175512L9310
	AI950B Temperature (TI4-B) Pt100, Pt1000, Ni100 in 2-/3-/4-technology Thermocouples type B, E, J, K, L, N, R, S, T Isolated inputs channel by channel	3KDE175522L9500

Analog Output		Article no.
	AO910B Analog output (AO4-B) Output 0/4...20 mA	3KDE175532L9100
	AO920B Analog output, isolated (AO4I-B) Output 0/4...20 mA Isolated outputs channel by channel	3KDE175532L9200
	AO930B Analog output HART (AO4H-B) Output 0/4...20 mA	3KDE175532L9300

S900 Remote I/O System

Safe area system components

Termination Unit	Article no.	
 <p>TU921N Redundant Termination Unit (TU16R) For 16 I/O-modules Redundant communication and power (Delivery includes CD910)</p>	3KDE175113L9210	
Power Supply	Article no.	
 <p>SA920N Power Supply For 24 V DC Do not mix SA910N with SA920N for redundancy (observe Release Notes)</p>	3BDH000600R1	
Communication Interface	Article no.	
 <p>CI920AN Communication Interface V 2.1 (CIPBA) Use only CI920AN with the same firmware for redundancy for PROFIBUS DP-V1 (observe Release Notes)</p>	3BDH000692R1	
Digital Input or Output	Article no.	
 <p>DX910N Digital Input or Output (DIO8) Input for dry contact or NAMUR initiator Output for low power valves</p> <p>DO910N Digital Output (DO4) Output for valves</p> <p>DO930N Relay Output (RO6) With 4 normally-open contacts and 2 changeover contacts</p> <p>DP910N Frequency Input (FI2) Input for dry contact or NAMUR initiator</p>	<p>3KDE175313L9100</p> <p>3KDE175323L9100</p> <p>3BDS014114</p> <p>3KDE175363L9100</p>	

S900 Remote I/O System

Safe area system components

Analog Input		Article no.
	AI910N Analog input (AI4) Transmitter power supply, 4...20 mA	3KDE175513L9100
	AI930N Analog Input, HART (AI4H) Transmitter power supply, 4...20 mA	3KDE175513L9300
	AI931N Analog Input, HART (AI4H) Passive input, 0/4...20 mA	3KDE175513L9310
	AI950N Temperature (TI4) Pt100, Pt1000, Ni100 in 2-/3-/4-technology Thermocouples type B, E, J, K, L, N, R, S, T Isolated inputs channel by channel	3KDE175523L9500

Analog Output		Article no.
	AO910N Analog output (AO4) Output 0/4...20 mA	3KDE175533L9100
	AO920N Analog output, isolated (AO4I) Output 0/4...20 mA Isolated outputs channel by channel	3KDE175533L9200
	AO930N Analog output HART (AO4H) Output 0/4...20 mA	3KDE175533L9300

S900 Remote I/O System

Accessories

Fieldbus isolating repeater	Article no.
BI914S Fieldbus isolating repeater Separates an intrinsically safe RS485 fieldbus from a non intrinsically safe RS485 fieldbus with bus termination mounted in DIN rail mounted housing with IP20 protection one channel version BARTEC - 07-7311-97WP/K1E0	3BDH000649R1
BI923S Ring-coupler RS485 / FO - intrinsically safe - Slave Separates an intrinsically safe fibre optic ring from a non intrinsically safe RS485 fieldbus BARTEC - 07-7311-97WP5400 mounted in DIN rail mounted housing with IP20 protection (Slave) Optical Plug FSMA	3KDE175831L9230
BI924S Ring-coupler RS485 / FO intrinsically safe - Master Separates an intrinsically safe fibre optic ring from a non intrinsically safe RS485 fieldbus BARTEC - 07-7311-97WP5400 mounted in DIN rail mounted housing with IP20 protection (Master) Optical Plug FSMA	3KDE175831L9240
BI934S Ring-coupler RS485 / FO intrinsically safe – Slave Separates an intrinsically safe fibre optic ring from one intrinsically safe RS485 fieldbus segment Mounted in separate field housing BARTEC - 07-3103-2512/9003 Optical Plug FSMA	3BDH000674R0001

Accessories	Article no.
 <p>IP920 Module housing</p>	
BP914S Intrinsically safe PROFIBUS-DP connector for CI920AS and CI920AB D-SUB Connector (color blue) for operating the intrinsically safe PROFIBUS-DP with CI920AS and CI920AB.	3BSE067082R1
Siemens 6ES7972-0DA60-0XA0 Connector can only be used with CI920AS and CI920AB. Do not use in combination with CI920S or CI920B. This would violate the explosion protection and could cause destruction of CI920S or CI920B. For CI920S and CI920B connector BP910S has to be ordered as spare part.	
IP920 Module housing IP20 protection for empty slots on the termination unit for use in S900 S, B, and N systems	3KDE175831L9200
IL910 Insert labels For labeling the modules.	3KDE175839L9101

Software	Article no.
CD910 Additional Software CD-ROM incl S900 Documentation, Certificates, GSD (file) CD-ROM will be delivered with all TU921 and CB220 deliveries.	3KDE175839L9100

S900 Remote I/O System

Field Housing S900-FH660S

General Information

The Ex e field housings FH660S from stainless steel (1.4301) serves for the reception of one redundant termination unit (backplane) TU16R-Ex (Order-No. TU921S) as well as further components with ATEX-certification for the hazardous area in zone 1.

Dimensions 600x600x300 mm / for max 100 field cables

The field housings are pre-mounted with stopping plugs instead of cable glands. The cable glands have to be ordered separately at manufacturer Hummel or manufacturer Bimed.

To fulfill the ATEX-certification the following cable glands are recommended:

Manufacturer Hummel:

- Type HSK-M-EMV-Ex M16 (article no. 1646160050)
- Type HSK-M-EMV-Ex M20 (article no. 1646200051)
- Type HSK-M-EMV-Ex M32 (article no. 1646320050)

Manufacturer Bimed:

- Type EBS M16 (article no. EBS01M)
- Type EBS M20 (article no. EBS1M)
- Type EBS M25 (article no. EBS2M)

All S900 modules and power supply components have to be ordered separately!

Additional costs of air transport and courier transport ask under e-mail:

Orderbox-CtrlPr DEAPR/DEAPR/ABB or orderbox.control-products@de.abb.com

Internal Installation



With system certificate.

FH660S-2000 Field housing

Including the following components:

- Termination Unit (backplane) TU921S
- 4 Terminals (UK10N)

Field housings are delivered without cable glands.

Cable glands have to be ordered separately (see General information and Product Update 2PAA112874).

FH660S-2020 Field housing

Including the following components:

- Termination Unit (backplane) TU921S
- 4 Terminals (UK10N)
- 2 Switches

Field housings are delivered without cable glands.

Cable glands have to be ordered separately (see General information and Product Update 2PAA112874).

Article no.

3KDE175804V2000

3KDE175804V2020

S900 Remote I/O System

Field Housing S900-FH680S

General Information

The Ex e field housings FH680S from stainless steel (1.4301) serves for the reception of one redundant termination unit (backplane) TU16R-Ex (Order-No. TU921S) as well as further components with ATEX-certification for the hazardous area in zone 1.

Dimensions 600x800x300 mm / for max 100 field cables

The field housings are pre-mounted with stopping plugs instead of cable glands. The cable glands have to be ordered separately at manufacturer Hummel or manufacturer Bimed.

To fulfill the ATEX-certification the following cable glands are recommended:

Manufacturer Hummel:

- Type HSK-M-EMV-Ex M16 (article no. 1646160050)
- Type HSK-M-EMV-Ex M20 (article no. 1646200051)
- Type HSK-M-EMV-Ex M32 (article no. 1646320050)

Manufacturer Bimed:

- Type EBS M16 (article no. EBS01M)
- Type EBS M20 (article no. EBS1M)
- Type EBS M25 (article no. EBS2M)

All S900 modules and power supply components have to be ordered separately!

Additional costs of air transport and courier transport ask under e-mail:

Orderbox-CtrlPr DEAPR/DEAPR/ABB or orderbox.control-products@de.abb.com

Internal Installation	Article no.	
With system certificate.		
<p>FH660S-2020 Field housing Including the following components:</p> <ul style="list-style-type: none"> • Termination Unit (backplane) TU921S • 4 Terminals (UK10N) • 2 Switches <p>Field housings are delivered without cable glands. Cable glands have to be ordered separately (see General information and Product Update 2PAA112874)</p>	3KDE175811V2020	

Fieldbus Network

FOUNDATION Fieldbus Network Components

FOUNDATION Fieldbus HSE/H1 Linking Device

LD 800HSE EX links the FOUNDATION Fieldbus HSE protocol to the FOUNDATION Fieldbus H1 protocol and vice versa. Up to 4 external powered H1 lines can be connected to one LD 800HSE EX. Two LD 800HSE EX can be combined to a redundant set of devices.

In this case the Redundancy Link cable is required.

Linking Devices	Article no.	
 <p>LD 810 HSE EX Linking Device LD 810 HSE EX module for DIN rail mounting with 4 H1 links and one HSE connector. The module itself needs external 24 VDC power supply. H1 links must be powered separately. Restrictions: Linking Device LD 810HSE Ex is not suitable for replacing one of the LD 800 Linking Devices in a redundant pair.</p> <p>To clarify, both devices in the redundant pair must be replaced with LD 810HSE Ex. Redundancy cable for LD 810HSE Ex can be made / procured by the end customer directly & need not be ordered through ABB.</p>	3BSE091722R1	

Accessories Linking Device LD 800HSE	Article no.	
<p>Redundancy Link Cable, 0,5m Redundancy Link Cable links two LD 800HSE to a redundant set of devices.</p>	3BDH000281R1	

Media and Documentation	Article no.	
<p>Media CD-ROM LD 800HSE, Version 3.5.0, English Documentation in pdf-format, tools, capabilities file, and bitmaps for LD 800HSE.</p>	3BDD011678R0701	
<p>Media CD-ROM LD 800HSE/LD 800HSE Ex, Version 3.6.0, English Documentation in pdf-format, tools, capabilities file, and bitmaps for LD 800HSE/LD 800HSE EX.</p>	3BDD011678R0801	
<p>Device Management FOUNDATION Fieldbus Linking Device, LD 800HSE 3.5.0/0 Describes in detail the FOUNDATION Fieldbus Linking Device LD 800HSE features, hardware installation, configuration, and diagnostics.</p>	3BDD011677-510	
<p>Device Management FOUNDATION Fieldbus Linking Device, LD 800HSE 3.6.0 Describes in detail the FOUNDATION Fieldbus Linking Device LD 800HSE/LD 800HSE EX features, hardware installation, configuration, and diagnostics.</p>	3BDD011677-600	

Fieldbus Network

PROFIBUS Network Components

PROFIBUS Redundancy Link Module RLM01	Article no.	
 <p>The RLM01 is delivered with a printed manual.</p> <p>RLM01, PROFIBUS Redundancy Link Module Converts a non-redundant PROFIBUS line to two redundant RS485 lines or vice versa. Germanischer Lloyd (GL) certified (cat. A,B,C,D) in connection with power supply filter (3BDZ000397R1). English and German manual.</p>	3BDZ000398R1	
<p>Power Supply Filter (surge) 24 V DC Mandatory to fulfill the requirements of Germanischer Lloyd (GL). WAGO article no. 750-626</p>	3BDZ000397R1	

PROFIBUS DP Accessories	Article no.	
There are no more PCO 010 on stock, so PCO 010 has been replaced by PCO 011.		
PCO 011, PROFIBUS DP connector Max. 12 Mbit/s, 35° cable outlet, IP40, switchable bus termination Phoenix Contact article no. 2708232.	3BDZ000371R1	
PCO 012, PROFIBUS DP connector Max. 12 Mbit/s, 35° cable outlet, IP40, switchable bus termination, programming connection SUB-D Phoenix Contact article no. 2708245	3BDZ000372R1	

Extended warranty time

S800 I/O, S900 I/O, Fieldbus and AC800M

Extended warranty time on hardware for S800 I/O, S900 I/O, Fieldbus and AC 800M	Article no.	
<p>Terms and conditions for the supply of products from Local Division Process Automation, LBU Control Technologies within ABB AB in Sweden is valid.</p> <p>Note that the price for the Extended Warranty Time order will be calculated as a percentage of the affected S800 I/O, S900 I/O, Fieldbus and AC 800M articles in the accompanying order.</p> <p>Item A100 => 3% of the affected HW articles within the whole order Item A110 => 6% of the affected HW articles within the whole order Item A120 => 9% of the affected HW articles within the whole order</p>		
Extended Warranty, 12 additional months S800 I/O, S900 I/O, Fieldbus and AC 800M	3BSE049878R1	
Extended Warranty, 24 additional months S800 I/O, S900 I/O, Fieldbus and AC 800M	3BSE049878R2	
Extended Warranty, 36 additional months S800 I/O, S900 I/O, Fieldbus and AC 800M	3BSE049878R3	

800xA 6.1 System Media

Media

ABB Ability™ System 800xA

ABB Ability™ System 800xA – Media	Article no.	
 <p>The articles in Section 1 may only be selected when ordering a new 800xA system, or if the end user has a valid Automation Sentinel agreement.</p>		
System 800xA 6.1, Media Box (SSD) Including: System 800xA 6.1, and User Documentation on a Solid State Drive device.	3BSE089961R1	

Media

Library

Library – Media	Article no.
Media can be downloaded from MyABB/My Control System.	

Media

Dongles

Dongles	Article no.
 <p>License dongle for USB Port For use in 800xA or Compact HMI systems. To be used with 800xA 5.1 Rev A and later.</p>	3BSE064644R1

Base System

Engineering Systems

Engineering Systems	Article no.
<p>Engineering System small 6.1 An engineering system which only can run in engineering mode. System Small works up to 5 engineering clients.</p> <p>For license details, please see pricelist 3BSE089997/A.</p>	3BSE089959R1
<p>Engineering System large 6.1 An engineering system which only can run in engineering mode. System Large works with more than 5 engineering clients.</p> <p>For license details, please see pricelist 3BSE089997/A.</p>	3BSE089960R1

Base System

Engineering Systems options

Engineering Systems options	Article no.
<p>Batch for Engineering, 800xA 6.1 Batch Server (singular/redundant), Batch Clients, 40 Batch Equipment, 1000 Batch Advanced phases, 20,000 Batch Spreadsheet Scheduler connections, 9 Batch Schedule Inter-phase.</p>	3BSE093116R1
<p>Information Manager for Engineering 6.1 License includes: IM Historian Server, 2 History logs (single/dual/consolidated), 100,000 Display Builder for MDI Client, 15 Multiscreen display interface (MDI), 150 Desktop Trends, 150 Excel Data Access, 150 ODBC Access to Historian Logs and Events, 3 ODBC-Client Connection OLE-DB Access to Historian Logs and Events OLE-DB-Client Connection.</p>	3BSE093117R1

800xA 6.1 System

Field-Kit System

Base System

Field-Kit systems

Field Kit 6.1	Article no.	
<p>License for usage of software to configure and check Select I/O as well as S800 on Ethernet independent of an 800xA system.</p> <p>The software can be installed on a Windows 10 Laptop or PC in a single node configuration.</p> <p>Usage includes Device Management for HART features as applicable for configuration and test of HART field devices. Testing of I/O loops is supported by user interface elements,</p> <p>which guide through the test procedure and log test results. Field Kit allows to transfer I/O configuration files and test reports for further processing in 800xA systems.</p>	3BSE093118R1	

Panel 800 version 6.2

Panel 800 is a user-friendly, intuitive and ergonomic operator panel that combines slim, space saving dimensions with a comprehensive range of advanced functions.

Panel 800 family comprises of user-friendly, intuitive and ergonomic operator panels that combine slim, space-saving dimensions with a comprehensive range of advanced functions.

Adding to the already well established feature rich Panel 800 version 6.2 our new Rugged and Black panels are designed to perform in challenging harsh environments.

Whether it is heavy outdoor use, usage in areas with explosion risk, or ship bridge use in marine applications, they are ready to provide you with the information needed.

Designed to make process automation easy, all panels are equipped with advanced functionality for process and equipment control, maneuvered by touching the LCD display.

Combined with market-leading performance and stunning graphical ability, Panel 800 erodes the line between ordinary Operator Panels and PC-based HMIs.

Panels are configured using ABB's Panel Builder tool that contains a wide range of advanced functions. The functions are tested and developed with customer needs and preferences in focus.



Specifications Panel 800 version 6.2

Standard panels



Panel	PP875	PP881	PP883	PP886	PP895
Display size	7"	10.4"	12.1"	15.4"	21.5"
Display resolution, ratio	800 × 480 (16:9)	1024 × 600 (16:9)	1280 × 800 (16:10)	1280 × 800 (16:10)	1920 × 1080 (16:9)
Processor	ARM9 (1 GHz)				
Main memory	512 MB	1.0 GB	1.0 GB	1.0 GB	2.0 GB
External storage media	1 × SD card slot (or SDHC with latest image loaded).				
Dimension WxHxD (mm)	204 × 243 × 50	292 × 194 × 52	340 × 242 × 37	410 × 286 × 61	556 × 347 × 65
Net weight (kg)	0.8	1.65	2.6	3.85	7.38
Power supply	+24 VDC (18-32 VDC)				
Operating temperature	-10 to +60 °C				0 °C to +50 °C
Certification					
CE	CE, FCC, KCC				
UL	UL610-2-201				
Marine	DNV, KR, GL, LR, ABS, CCS				-
RoHS compliance	DIRECTIVE/2011/65/EU				
WEEE compliance	DIRECTIVE/2012/19/EU				

Specifications Panel 800 version 6.2

Black panels



Panel	PP875M	PP875H	PP886M
Display size	7"	7"	15.4"
Display resolution, ratio	800 × 480 (16:9)	800 × 480 (16:9)	1280 × 800 (16:10)
Processor	ARM9 (1 GHz)		
Main memory	512 MB	2 GB	1 GB
External storage media	1 × SD card slot (or SDHC with latest image loaded)		
Dimension WxHxD (mm)	204 × 143 × 50		410 × 286 × 61
Net weight (kg)	0.8	0.8	3.85
Power supply	24 VDC (18-32 VDC)		
Operating temperature	-10 to +60 °C		
Certification			
CE	CE, FCC, KCC		
UL	UL61010-2-201		
Marine	DNV, KR, GL, LR, ABS, CCS		
RoHS compliance	DIRECTIVE/2011/65/EU		
WEEE compliance	DIRECTIVE/2012/19/EU		

Specifications Panel 800 version 6.2

Rugged panels



Panel	PP886R	PP887H	PP887S
Display size	15.4"		
Display resolution, ratio	1280 x 800 (16:10)		
Processor	ARM9 (800 MHz)	ARM9 (1 GHz)	ARM9 (1 GHz)
Main memory	1 GB		
External storage media	1 x SD card slot (or SDHC with latest image loaded)		
Dimension WxHxD (mm)	410 x 286 x 73		
Net weight (kg)	4.1	4.1	4.8
Power supply	24 VDC (18-32 VDC)		
Operating temperature	-30 to +70 °C		
Certification			
CE	CE, FCC, KCC		
UL	UL-61010-2-201		
Marine	DNV, KR, GL, LR, ABS, CCS		
Hazardous	UI/cUL C1D2, ATEX (Zone 2, Zone 22), IECEx (Zone 2, Zone 22)		
RoHS compliance	DIRECTIVE/2011/65/EU		
WEEE compliance	DIRECTIVE/2012/19/EU		

09

Panel 800 version 6.2

Lifecycle Management Program

Lifecycle Management Program

Automation Sentinel is the ABB control system lifecycle management program for the Extended Automation, Freelance, Compact Product Suite, Symphony Plus and OCS product lines. ABB recommends its customers to use Automation Sentinel for all its installed control systems. With this program, customers can keep control software up-to-date and maintain a flexible path forward to new system software technology. It provides services to maintain and continually advance and enhance your ABB control system installation. You may choose the level of maintenance and upgrade support that works best for your immediate needs and long-term production targets.

Read more about our Automation Sentinel Program here:
<https://new.abb.com/control-systems/service/offerings/service-agreements>

Upgrade Orders	Article no.
Panel Builder 800 Version 6, upgrade only Media folder with Panel Builder 800 Version 6 containing the latest version of: <ul style="list-style-type: none"> • Panel Builder 800 Version 6 • Panel 800 Runtime • Firmware for panels • Manuals as pdf-files • Release Notes • Renewed license This item can be ordered by users with a valid Automation Sentinel agreement for Panel Builder 800.	3BSE069301R1





Panel 800 version 6.2



Panel Builder 800



Panel Builder 800	Article no.
<p>Panel Builder 800 is the engineering tool for Panel 800.</p>  <p>Panel Builder 800 Version 6 Media folder with Panel Builder 800 Version 6 containing the latest version of:</p> <ul style="list-style-type: none"> • Panel Builder 800 Version 6 • Panel 800 Runtime • Firmware for panels • Manuals as pdf-files • Release Notes • License for one Panel Builder 800 Version 6 	<p>3BSE069300R1</p>

Panel 800 Version 6.2

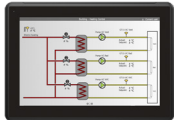
Operator Panels

Standard Panels	Article no.
 <p>PP875 Standard panel 7" TFT 800x480 widescreen (16:9). Requires Panel Builder 800 Version 6.2 for configuration.</p> <p>To protect the front, it's recommended to use the RX874 Touch cover. Replaces PP874.</p>	<p>3BSE092977R1</p>
 <p>PP881 Standard panel 10" TFT 1024x600 widescreen (16:9). Requires Panel Builder 800 Version 6.2 for configuration.</p> <p>To protect the front, it's recommended to use the RX881 Touch cover. Replaces PP877. For mounting in the same cut-out as PP877, RX800 Adapter plate is required.</p>	<p>3BSE092978R1</p>
 <p>PP883 Standard panel 12" TFT 1280x800 widescreen (16:10). Requires Panel Builder 800 Version 6.2 for configuration.</p> <p>To protect the front, it's recommended to use the RX883 Touch cover. Replaces PP882.</p>	<p>3BSE092979R1</p>
 <p>PP886 Standard panel 15" TFT 1280x800 widescreen (16:10). Requires Panel Builder 800 Version 6.2 for configuration.</p> <p>To protect the front, it's recommended to use the RX886 Touch cover. Replaces PP885.</p>	<p>3BSE092980R1</p>
 <p>PP895 Standard panel 21" TFT 1920x1080 widescreen (16:9). Requires Panel Builder 800 Version 6.2 for configuration.</p> <p>To protect the front, it's recommended to use the RX895 Touch cover.</p>	<p>3BSE092981R1</p>

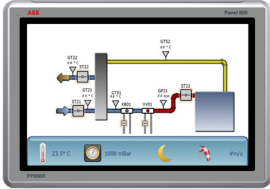
Black Panels	Article no.	
 <p>PP875M Black Panel 7" TFT 800x480 widescreen (16:9). Requires Panel Builder 800 Version 6.2 for configuration.</p> <p>To protect the front, it's recommended to use the RX874 Touch cover. Replaces PP874M.</p>	3BSE092982R1	
 <p>PP875H Black Panel, High Brightness 7" TFT 800x480 widescreen (16:9) Brightness 1000 cd/m². Requires Panel Builder 800 Version 6.2 for configuration.</p> <p>To protect the front, it's recommended to use the RX874 Touch cover.</p>	3BSE092983R1	
 <p>PP886M Black Panel 15" High Brightness 1000 cd/m² TFT 1280x800 widescreen (16:10). Requires Panel Builder 800 Version 6.2 for configuration.</p> <p>To protect the front, it's recommended to use the RX886 Touch cover. Replaces PP885M.</p>	3BSE092984R1	

Rugged Panels	Article no.	
 <p>PP886R Rugged Panel 15" TFT 1280x800 widescreen (16:10). Requires Panel Builder 800 Version 6.2 for configuration.</p> <p>To protect the front, it's recommended to use the RX886 Touch cover. Replaces PP885R. One Ethernet port.</p>	3BSE092985R1	
 <p>PP887H Rugged Panel, High Brightness 15" TFT 1280x800 widescreen (16:10) Brightness 1000 cd/m². Requires Panel Builder 800 Version 6.2 for configuration.</p> <p>To protect the front, it's recommended to use the RX886 Touch cover. Replaces PP886H.</p>	3BSE092986R1	
 <p>PP887S Rugged Panel, Sealed 15" TFT 1280x800 widescreen (16:10) Brightness 1000 cd/m². Sealed on all sides, can be mounted directly on an arm.</p> <p>Requires Panel Builder 800 Version 6.2 for configuration. To protect the front, it's recommended to use the RX886 Touch cover.</p> <p>PP887S is a fully sealed version with M12 connectors with IP66 ingress protection rating and ATEX/IECEX Zone 2 and Zone 22 (IP65) certification.</p>	3BSE092987R1	



Panel 800 Version 6.2







Dongles

Dongles	Article no.	
<p>Requires Panel 800 Runtime Version 6.2 to be installed on the PC. The USB dongle enables the runtime and the amount of signals.</p>		
 <p>Panel 800 Version 6.2 dongle 250 tags. USB dongle for 250 signals (tags).</p>	3BSE093564R1	
<p>Panel 800 Version 6.2 dongle 2000 tags. USB dongle for 2000 signals (tags).</p>	3BSE093565R1	
<p>Panel 800 Version 6.2 dongle 4000 tags. USB dongle for 4000 signals (tags).</p>	3BSE093566R1	

Panel 800 Version 6.2

Accessories

Communication Interface for Panel 800	Article no.	
 <p>CB802 Profibus DP Interface PROFIBUS DP slave expansion module for Panel 800 Version 6 panels. Not possible to use for PP880R, PP885H, PP885M, PP885R, PP886H, PP887H and PP887S. Not marine certified.</p>	3BSE069285R1	
 <p>CB810 USB to Ethernet adapter for programming USB to Ethernet adapter with software. Cross over Ethernet patch cable included.</p>	3BSE042255R1	

Connection Cables for Panel 800	Article no.	
 <p>TK858V002 Adapter cable Adapter cable RS232 - RS485 0.2 m 9 pin D-Sub to 25 pin D-Sub. For using version 5 RS422/485 cables on Version 6 panels.</p>	3BSE069474R1	
 <p>TK859V000 Gender changer Gender changer 9 pin D-Sub male/male.</p>	3BSE069475R1	
 <p>TK860V001 Splitter cable Splitter cable Version 6 panel. Y-split for use with one RS232 and one RS422 connection. Not possible to use with PP887S.</p>	3BSE069476R1	
 <p>TK868V002 Splitter 3 way Splitter cable. Used when two serial RS485 connections are needed (1xRS232 + 2xRS485). Not possible to use with PP887S.</p>	3BSE093567R1	
 <p>TK865V030 Cable m. 8p to blank 3m (COM) Cable M12 male 8 pin to blank, 3 m (COM). Only for PP887S with M12 contacts.</p>	3BSE092988R1	
 <p>TK865V100 Cable m. 8p to blank 10m (COM) Cable M12 male 8 pin to blank, 10 m (COM). Only for PP887S with M12 contacts.</p>	3BSE092989R1	

Connection Cables for Panel 800		Article no.
	TK866V030 Cable m. 4p to blank 3m (LAN) Cable M12 male 4 pin to blank, 3 m (LAN). Only for PP887S with M12 contacts.	3BSE092990R1
	TK866V100 Cable m. 4p to blank 10m (LAN) Cable M12 male 4 pin to blank, 10 m (LAN). Only for PP887S with M12 contacts.	3BSE092991R1
	TK867V030 Cable f. 4p to blank 3m (POW) Cable M12 female 4 pin to blank, 3 m (POWER). Only for PP887S with M12 contacts.	3BSE092992R1
	TK867V100 Cable f. 4p to blank 10m (POW) Cable M12 female 4 pin to blank, 10 m (POWER). Only for PP887S with M12 contacts.	3BSE092993R1
	TK865V000 Conn. 8p male 5.5-7.5mm (COM) Connector M12 male 8 pin 5.5 - 7.5 mm, Gland (COM) Only for PP887S with M12 contacts.	3BSE092994R1
	TK866V000 Conn. 4p male 5.5-7.5mm (LAN) Connector M12 male 4 pin 5.5 - 7.5 mm, Gland (LAN) Only for PP887S with M12 contacts.	3BSE092995R1
	TK867V000 Conn. 4p fem. 5.5-7.5mm (POW) Connector M12 female 4 pin 5.5 - 7.5 mm, Gland (POWER) Only for PP887S with M12 contacts.	3BSE092996R1

Front Protections		Article no.
	RX874 Touch cover 7" Plastic cover for protection. Possible to use for PP880R, PP874, PP874M, PP875, PP875M and PP875H.	3BSE069287R1
	RX881 Touch cover 10" Plastic cover for protection. Possible to use for PP881.	3BSE093559R1
	RX883 Touch cover 12" Plastic cover for protection. Possible to use for PP883.	3BSE093560R1
	RX886 Touch cover 15" Plastic cover for protection. Possible to use for PP886, PP886M, PP886R, PP887H and PP887S.	3BSE093561R1
	RX895 Touch cover 21" Plastic cover for protection. Possible to use for PP895.	3BSE093562R1

Adapter Plates		Article no.
	RX800 Adapter plate for PP877 to PP881 Adapter plate for installing the replacement panel PP881 on a PP877 mounting.	3BSE093563R1

Miscellaneous		Article no.
	MB802V2 SD card 2GB Secure Digital memory card 2GB Industrial grade for Version 6 panels.	3BSE069477R1

System 800xA Networks

Control. Monitor. Communicate.

System 800xA Networks provide pre-configured network components that are tested with System 800xA to ensure top quality performance and provide protection against cyber threats.

Wired switches (NE800) - includes a set of rack- and DIN-mounted switches and a wide range of modular transceivers.

Redundant Network Routing Protocol (RNRP) routers are available as part of the System 800xA Networks portfolio developed for use with System 800xA.

System 800xA Networks enables you to take control of your network infrastructure, and benefit from the full potential of a robust, highly performing, and secure 800xA system.



NE870



NE801



PT801

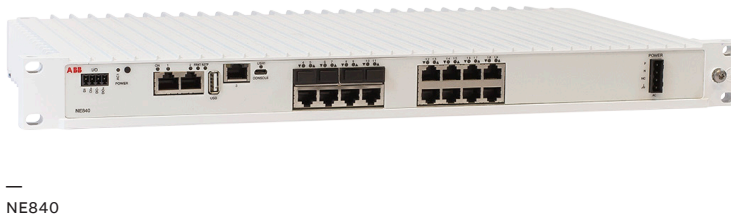

NE840



NE810

System 800xA Networks selection guide

Specific feature *	NE801	NE802	NE810	NE820	NE840
Article number	3BSE080209R1	3BSE080237R1	3BSE080207R1	3BSE080208R1	3BSE080211R1
Managed	Lightly managed (configurable using physical dip-switches)	Lightly managed (configurable using physical dip-switches)	Managed	Managed	Managed
Dimension (W x H x D)	34 x 123 x 121 mm	34 x 123 x 121 mm	52 x 100 x 101 mm	175 x 105 x 122 mm	466 x 258 x 43 mm
Weight	0.2 kg	0.2 kg	0.7 kg	2.2 kg	3.8 kg
Degree of protection	IP21	IP21	IP40	IP40	IP40
Operating voltage	9.6 to 57.6 VDC redundant power input	9.6 to 57.6 VDC redundant power input	19 to 60 VDC redundant power input	16 to 60 VDC redundant power input	90 to 264VAC, 47 to 63 Hz
Rated current	350 mA @ 12 VDC	100 mA @ 12 VDC	240 mA @ 24 VDC 120 mA @ 48 VDC	930 (1120 ⁽¹⁾) mA @ 20 VDC 380 (450 ⁽¹⁾) mA @ 48 VDC	350 mA @ 120 VAC 60 Hz 220 mA @ 240 VAC 50 Hz
Ethernet TX	4 x 10/100 Mbit/s	4 x 10/100/1000 Mbit/s	8 x 10/100 Mbit/s	7 x 10/100/1000 Mbit/s, 8 x 10/100 Mbit/s	7 x 10/100/1000 Mbit/s, 8 x 10/100 Mbit/s
Ethernet SFP pluggable connections (FX or TX)	1 x LC-connection, 100 Mbit/s	1 x 10/100/1000 Mbit/s	2 x 10/100/1000 Mbit/s	4 x 10/100/1000 Mbit/s	4 x 10/100/1000 Mbit/s
Digital I/O	-	-	1 x 4-ports detachable screw terminal	1 x 4-ports detachable screw terminal	1 x 4-ports detachable screw terminal
Console	-	-	1 x 1 x 2.5 mm jack	1 x USB Micro-B connector	1 x USB Micro-B connector
Operating Temperature	-25 to +70 °C	-40 to +74 °C	-40 to +70 °C	-40 to +70 °C	-40 to +55 °C
Temperature Storage & Transport	-25 to +70 °C	-40 to +85 °C	-50 to +85 °C	-50 to +85 °C	-40 to +85 °C
Network redundancy	-	-	Fast reconfiguration of network typology (FRNT) FRNT ring coupling	Fast reconfiguration of network typology (FRNT) FRNT ring coupling	Fast reconfiguration of network typology (FRNT) FRNT ring coupling
Mounting	DIN-mounted	DIN-mounted	DIN-mounted	DIN-mounted	Rack-mounted
Marine certificate	DNV	DNV	DNV	DNV	DNV
G3 compliant	Compliant	Compliant	Compliant	Compliant	Compliant
MTBF ⁽²⁾	500,000 hours	1,182,374 hours	630,000 hours	303,000 hours	123,000 hours

⁽¹⁾ With 500 mA USB load

⁽²⁾ According to MIL-HDBK-217K

* For detailed information on each module, please visit: www.800xahardwareselector.com

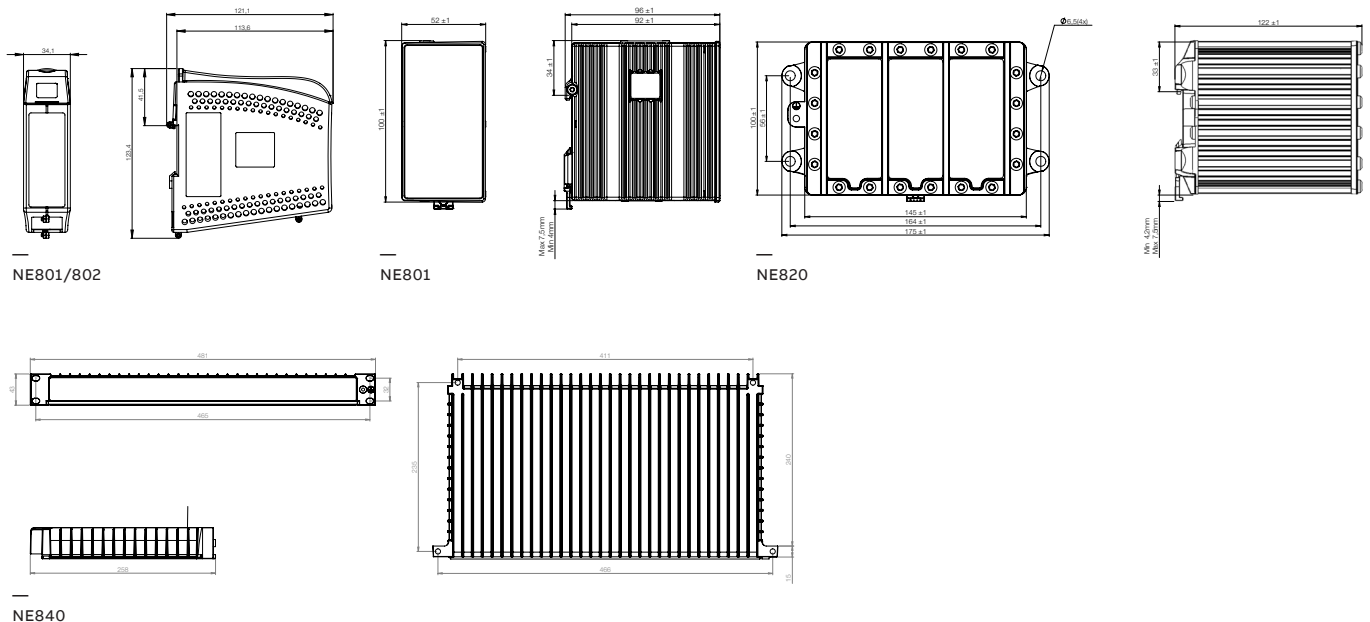

Specific feature	NE870	NE871
Article number	3BSE080239R1	3BSE080240R1
Managed	Yes	Yes
Routing	Yes	Yes
Firewall	Yes	Yes
Dimension (W x H x D)	134 x 100 x 122 mm	134 x 100 x 122 mm
Weight	1.5 kg	1.5 kg
Degree of protection	IP40	IP40
Operating voltage	16 to 60 VDC	16 to 60 VDC
Rated current	0.43 (0.60 ⁽¹⁾) A @ 20 VDC 0.19 (0.25 ⁽¹⁾) A @ 48 VDC	0.31 (0.48 ⁽¹⁾) A @ 20 VDC 0.15 (0.21 ⁽¹⁾) A @ 48 VDC
Ethernet TX	3 x 10/100/1000 Mbit/s, Ethernet TX, RJ-45 8 x 10/100 Mbit/s, Ethernet TX, RJ-45	3 x 10/100/1000 Mbit/s, Ethernet TX, RJ-45
Digital I/O	1 x 4-ports detachable screw terminal	1 x 4-ports detachable screw terminal
Console	1 x USB Micro-B connector	1 x USB Micro-B connector
Operating Temperature	-40 to +70 °C	-40 to +70 °C
Temperature Storage & Transport	-50 to +85 °C	-50 to +85 °C
Network redundancy	Redundant Network Routing Protocol (RNRP) Fast reconfiguration of network typology (FRNT) FRNT ring coppling	Redundant Network Routing Protocol (RNRP) Fast reconfiguration of network typology (FRNT) FRNT ring coppling
Mounting	DIN-mounted	DIN-mounted
Marine certificate	DNV	DNV
G3 compliant	Compliant	Compliant
MTBF ⁽²⁾	430,000 hours	430,000 hours

⁽¹⁾ With 500 mA USB load

⁽²⁾ according to MIL-HDBK-217K

Agency approvals and standards compliance *

EMC	EN 50121-4	Railway applications – Electromagnetic compatibility – Emission and immunity of the signalling and telecommunications apparatus
	EN 55022	Information technology equipment – Radio disturbance characteristics – Limits and methods of measurement
	EN 55024	Information technology equipment – Immunity characteristics Limits and methods of measurement
	EN 61000-6-1	Electromagnetic compatibility – Immunity for residential, commercial and light-industrial environments
	EN 61000-6-2	Electromagnetic compatibility – Immunity for industrial environments
	EN 61000-6-3	Electromagnetic compatibility – Emission standards for residential, commercial and light industrial environments
	EN 61000-6-4	Electromagnetic compatibility – Emission standard for industrial environments
		FCC part 15 Class A
Safety	UL/IEC/EN 60950-1, IT equipment	
Marine	DNV Standard for Certification no. 2.4	
RoHS compliance	EN 50581:2012	
WEEE compliance	DIRECTIVE/2012/19/EU	

* For detailed information on each module, please visit: www.800xahardwareselector.com

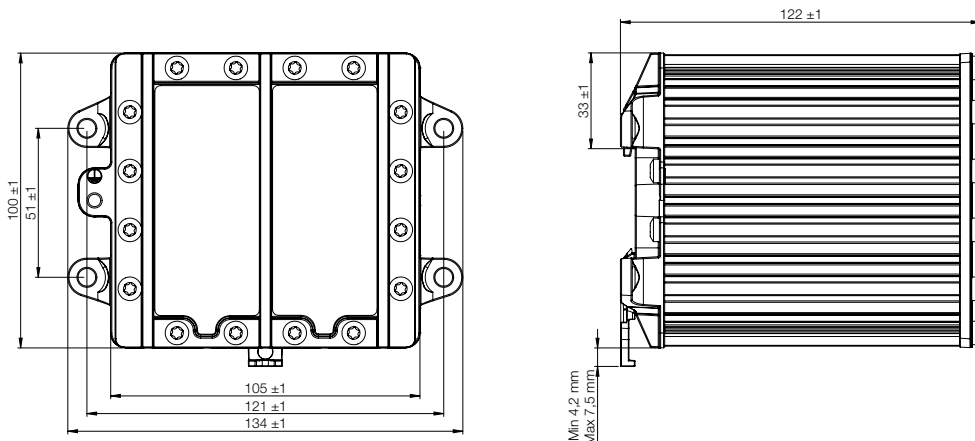



System 800xA Networks

Network switches

Network switches	Article no.	
 <p>NE801 DIN-mounted 5 ports lightly managed switch, 4 10/100Mbit RJ45 ports & 100Mbit LC optical port. Redundant 24V DC-power input.</p>	3BSE080209R1	
 <p>NE802 DIN-mounted 5 ports lightly managed switch, 4 10/100/1000Mbit RJ45 ports & 1Gbit SFP. Redundant 24V DC-power input.</p>	3BSE080237R1	
 <p>NE810 DIN-mounted 10 ports managed switch, 8 10/100Mbit RJ45 ports & 2 Gbit SFP ports. Redundant 24V DC-power input.</p>	3BSE080207R1	
 <p>NE820 DIN-mounted 19 ports managed switch, 8 10/100Mbit RJ45 ports, 7 Gbit RJ45 ports & 4 Gbit SFP ports. Redundant 24V DC-power input.</p>	3BSE080208R1	
 <p>NE840 Rack-mounted 19 ports managed switch, 8 10/100Mbit RJ45 ports, 7 Gbit RJ45 ports & 4 Gbit SFP ports. 110/230V AC-power input.</p>	3BSE080211R1	

System 800xA Networks

Network routers/firewalls

Network routers/firewalls	Article no.	
 <p>NE870 DIN-mounted 11 ports RNRP router and firewall, 3 10/100/1000Mbit RJ45 ports and 8 10/100Mbit RJ45 ports. Redundant 24V DC-power input.</p>	3BSE080239R1	
 <p>NE871 DIN-mounted 3 ports RNRP router and firewall, 3 10/100/1000Mbit RJ45 ports. Redundant 24V DC-power input.</p>	3BSE080240R1	

System 800xA Networks

Network accessories

Network accessories		Article no.
	TK863 Cable.USB 2,5mm plug for NE810	3BSE080212R1
	TK864 Micro USB Console cable for e.g. NE820, NE840, NE870 & NE871	3BSE080213R1

System 800xA Networks

Modular Transceivers (SFPs)

Modular Transceivers (SFPs)		Article no.
	The ABB range of Small Form-factor Pluggable (SFP) transceivers covers versions suitable for 100 Mbit/s and Gigabit applications. LC connectors are used as standard due their small size. Operating temperature specification: -40 to +85°C (-40 to +185°F)	
	PT801 Multimode, LC-connector, 2 km, 1310nm, 100Mbit/s	3BSE080214R1
	PT802 Singlemode, LC-connector, 20km, 1310nm, 100Mbit/s	3BSE080215R1
	PT803 Singlemode,BiDi, 20km, 1310nm TX, 1550nm RX, 100Mbit/s	3BSE080223R1
	PT804 Singlemode, BiDi, 20 km, 1550nm TX, 1310 RX, 100Mbit/s	3BSE080224R1
	PT805 Singlemode, LC-connector, 40km, 1310nm, 100Mbit/s	3BSE080216R1
	PT806 Singlemode, BIDI, 40Km, 1310nmTX, 1550RX, 100Mbit/s	3BSE080227R1
	PT807 Singlemode, BIDI, 40Km, 1550nmTX, 1310RX, 100Mbit/s	3BSE080228R1
	PT808 Singlemode, LC-connector, 80km,1550nm, 100Mbit/s	3BSE080217R1
	PT809 Singlemode, BiDi, 80km, 1310nm TX, 1550nm RX, 100Mbit/s	3BSE080235R1
	PT810 Singlemode, BiDi, 80km, 1550nm TX, 1310nm RX, 100Mbit/s	3BSE080236R1
	PT811 Singlemode, LC-connector, 120km,1550nm, 100Mbit/s	3BSE080218R1
	PT812 Singlemode, BiDi, 120km, 1550nm TX, 1490 nm RX, 100Mbit/s	3BSE080233R1
	PT813 Singlemode, BiDi, 120km, 1490nm TX, 1550nm RX, 100Mbit/s	3BSE080234R1

System 800xA Networks

Modular Transceivers (SFPs)



Modular Transceivers (SFPs)	Article no.
PT814 RJ-45, 100m, 10/100Mbit/s TX	3BSE080232R1
PT831 Multimode, LC-connector, 550m, 850nm, SX, 1000Mbit/s	3BSE080222R1
PT832 Multimode, LC-connector, 2km, 1310nm, SX+, 1000Mbit/s	3BSE080225R1
PT833 Singlemode, LC-connector, 10km, 1310nm, LX, 1000Mbit/s	3BSE080219R1
PT834 Singlemode, BiDi, 20km 1310nmTX, 1490nm RX, 1000Mbit/s	3BSE080229R1
PT835 Singlemode, BiDi, 20 km, 1490TX, 1310nm RX, 1000Mbit/s	3BSE080230R1
PT836 Singlemode, LC-connector, 50km, 1550nm, XD, 1000Mbit/s	3BSE080220R1
PT837 Singlemode, LC-connector, 80km, 1550nm, ZX, 1000Mbit/s	3BSE080221R1
PT838 Singlemode, LC-connector, 110km, 1550nm, EZX, 1000Mbit/s	3BSE080231R1
PT839 GCX100-Copper, RJ-45, 100m, 1000Base TX	3BSE080226R1

Specifications Optical Transceivers

Product title	Article number	Type	Link speed (Mbit/s)	Indicative range (km)	Power budget (dB)	TX/RX wavelength (nm)
PT801	3BSE080214R1	Multi mode	100	2	20	1310/1310
PT802	3BSE080215R1	Single mode	100	20	17	1310/1310
PT803	3BSE080223R1	Single mode, BiDi	100	20	18	1310/1550
PT804	3BSE080224R1	Single mode, BiDi	100	20	18	1550/1310
PT805	3BSE080216R1	Single mode	100	40	30	1310/1310
PT806	3BSE080227R1	Single mode, BiDi	100	40	26	1310/1550
PT807	3BSE080228R1	Single mode, BiDi	100	40	26	1550/1310
PT808	3BSE080217R1	Single mode	100	80	30	1550/1550
PT809	3BSE080235R1	Single mode, BiDi	100	80	29	1310/1550
PT810	3BSE080236R1	Single mode, BiDi	100	80	35	1550/1310
PT811	3BSE080218R1	Single mode	100	120	35	1550/1550
PT812	3BSE080233R1	Single mode, BiDi	100	120	32	1550/1490
PT813	3BSE080234R1	Single mode, BiDi	100	120	32	1490/1550
PT814	3BSE080232R1	RJ45	10/100	0.1	-	-
PT831	3BSE080222R1	Multi mode	1000	0.3–0.55	9	850/850
PT832	3BSE080225R1	Multi mode	1000	1–2	1	1310/1310
PT833	3BSE080219R1	Single mode	1000	10	11	1310/1310
PT834	3BSE080229R1	Single mode, BiDi	1000	20	15	1310/1490
PT835	3BSE080230R1	Single mode, BiDi	1000	20	15	1490/1310
PT836	3BSE080220R1	Single mode	1000	50	20	1550/1550
PT837	3BSE080221R1	Single mode	1000	80	24	1550/1550
PT838	3BSE080231R1	Single mode	1000	110	30	1550/1550
PT839	3BSE080226R1	RJ45	1000	0.1	-	-

Extended Warranty Time

S800 I/O, S900 I/O, Fieldbus and AC 800M

Extended warranty time on hardware for S800 I/O, S900 I/O, Fieldbus and AC 800M	Article no.	
<p>Terms and conditions for the supply of products from Local Division Process Automation, LBU Control Technologies within ABB AB in Sweden is valid.</p> <p>Note that the price for the Extended Warranty Time order will be calculated as a percentage of the affected S800 I/O, S900 I/O, Fieldbus and AC 800M articles in the accompanying order.</p> <ul style="list-style-type: none"> • Item A100 => 3% of the affected HW articles within the whole order • Item A110 => 6% of the affected HW articles within the whole order • Item A120 => 9% of the affected HW articles within the whole order 		
<p>Extended Warranty, 12 additional months S800 I/O, S900 I/O, Fieldbus and AC 800M</p>	3BSE049878R1	
<p>Extended Warranty, 24 additional months S800 I/O, S900 I/O, Fieldbus and AC 800M</p>	3BSE049878R2	
<p>Extended Warranty, 36 additional months S800 I/O, S900 I/O, Fieldbus and AC 800M</p>	3BSE049878R3	



S800 I/O



AC 800M controller



S900 I/O

ABB Ability™ System 800xA

References

This page gives you references and links to more useful ABB Ability™ System 800xA information. For more information about System 800xA please also visit our web: www.abb.com/800xA

System 800xA References

[1] System 800xA 6.1 System Guide, Technical data and configuration, 3BSE041434-610

[2] System 800xA Released User Documentation, 3BUA000263-610

[3] System 800xA Software product life cycle plan, 3BSE049081

[4] Automation Sentinel Product Guide, 3BSE047996

[5] For more information about System 800xA please visit: www.abb.com/800xA

[6] For more information about 800xA hardware please visit: www.800xahardwareselector.com

[7] For information and support about Distributed Control Systems, please visit: www.abb.com/controlsystems

System 800xA Hardware Selector

Choosing the right hardware made easy

When planning your new project or expansion, finding the right hardware can be a challenge. Check out the new web based tool that helps you find the hardware you need in a few clicks:

- Quick filtering according to your needs
- Compare different units at a glance
- Find matching termination units
- Make lists and export everything in nice looking datasheets

Start using the System 800xA Hardware Selector now at: www.800xahardwareselector.com

System 800xA hardware selector

[S800 I/O Environmental Declaration](#) [EXPORT DATA SHEET](#)

C1801

General info	
Protocol	PROFIBUS DP-V1
Article number	3BSE02366R1
Master or slave	Slave
Line redundancy	No
Module redundancy	No
Hot Swap	No
Used together with HI Controller	Yes
Detailed data	
Environmental and certification	
Dimensions	

S800 I/O is a comprehensive, distributed and modular process I/O system that communicates with parent controllers and PLCs over industry-standard field buses. The C1801 Fieldbus Communication Interface (FCI) module is a configurable communication interface that performs operations such as signal processing, gathering of supervision information, DSP handling, Hot Configuration InRun, HART

**solutions.abb/800xA
800xahardwareselector.com**

800xA is a registered or pending trademark of ABB. All rights to other trademarks reside with their respective owners.

We reserve the right to make technical changes to the products or modify the contents of this document without prior notice. With regard to purchase orders, the agreed particulars shall prevail. ABB does not assume any responsibility for any errors or incomplete information in this document.

We reserve all rights to this document and the items and images it contains. The reproduction, disclosure to third parties or the use of the content of this document –including parts thereof – are prohibited without ABB's prior written permission.

Copyright© 2020 ABB
All rights reserved